

# Notes on Differential Equations

Robert E. Terrell

## Preface

These *Notes on Differential Equations* are an introduction and invitation. The focus is on

1. important models
2. calculus (review?) in applied contexts

I may point out that the title is not *Solving* Differential Equations; we derive them, discuss them, review calculus background for them, apply them, sketch and compute them, and also solve them and interpret the solutions. This breadth is new to many students.

The notes, available for many years on my web page, have evolved from lectures I have given while teaching the Engineering Mathematics courses at Cornell University. They could be used for an introductory unified course on ordinary and partial differential equations. There is minimal manipulation and a lot of emphasis on the teaching of concepts by example.

For background on calculus see

- Lax, P., and Terrell, M., *Calculus With Applications*, Springer, 2014.

The focus on key models here was influenced by the Lax Terrell book. In a few places we assume familiarity with the divergence theorem. For further information see:

- Churchill, Ruel V., *Fourier Series and Boundary Value Problems*, McGraw Hill, 1941
- Hubbard, John H., and West, Beverly H., *Differential Equations, a Dynamical Systems Approach, Parts 1 and 2*, Springer, 1995 and 1996.
- and the software discussed in Lecture 5.

Some of the exercises have the format “*What’s rong with this?*”. These are either questions asked by students or errors taken from test papers of students in this class, so it could be quite beneficial to study them.

Robert E. Terrell

version 5: 2014

version 1: 1997

## Contents

<b>1</b>	<b>The Banker's Equation</b>	<b>1</b>
1.1	Slope Fields . . . . .	2
<b>2</b>	<b>A Gallery of Differential Equations</b>	<b>5</b>
<b>3</b>	<b>The Transport Equation</b>	<b>7</b>
3.1	A Conservation Law . . . . .	7
3.2	Traveling Waves . . . . .	8
<b>4</b>	<b>The Logistic Population Model</b>	<b>11</b>
<b>5</b>	<b>Existence and Uniqueness and Software</b>	<b>14</b>
<b>6</b>	<b>Newton's Law of Cooling</b>	<b>17</b>
6.1	Investments . . . . .	20
<b>7</b>	<b>Exact equations for Air and Steam</b>	<b>21</b>
<b>8</b>	<b>Euler's Numerical Method</b>	<b>24</b>
<b>9</b>	<b>Spring-mass oscillations</b>	<b>28</b>
9.1	Conservation laws and uniqueness . . . . .	31
<b>10</b>	<b>Applications of Complex Numbers</b>	<b>33</b>
10.1	Exponential and characteristic equation . . . . .	33
10.2	The Fundamental Theorem of Algebra . . . . .	38
10.3	A forced oscillator . . . . .	39
<b>11</b>	<b>Three masses oscillate</b>	<b>42</b>
<b>12</b>	<b>Boundary Value Problems</b>	<b>47</b>

<b>13 The Conduction of Heat</b>	<b>49</b>
13.1 Walk the line . . . . .	53
<b>14 Initial Boundary Value Problems for the Heat Equation</b>	<b>56</b>
14.1 Insulation . . . . .	58
14.2 Product Solutions . . . . .	59
14.3 Superposition . . . . .	61
<b>15 The Wave Equation</b>	<b>64</b>
<b>16 Application of Power Series: a Drum model</b>	<b>69</b>
16.1 A new Function for the Drum model, $J_0$ . . . . .	72
16.2 But what does the drum Sound like? . . . . .	74
<b>17 The Euler equation for Fluid Flow, and Acoustic Waves</b>	<b>77</b>
17.1 Sound . . . . .	80
<b>18 The Laplace Equation</b>	<b>81</b>
18.1 Laplace leads to Fourier . . . . .	84
18.2 Fourier's Dilemma . . . . .	86
18.3 Fourier answered by Orthogonality . . . . .	88
<b>19 Application to the weather?</b>	<b>92</b>

# 1 The Banker's Equation

TODAY: An example involving your bank account, and nice pictures called slope fields (or direction fields). How to read a differential equation.

Welcome to the world of differential equations! They describe many processes in the world around you, but of course we'll have to convince you of that. Today we are going to give an example, and find out what it means to read a differential equation.

A differential equation is an equation which contains a derivative of an unknown function. It tells something about a rate of change, from which we hope to deduce facts about the function. Here is a differential equation.

$$\frac{dy}{dt} = .01y$$

It might represent your bank account, where the balance is  $y(t)$  at a time  $t$  years after you open the account, and the account is earning 1% interest. Regardless of the specific interpretation, let's see what the equation says. Since we see the term  $dy/dt$  we can tell that  $y$  is a function of  $t$ , and that the rate of change is a multiple, namely .01, of the value of  $y$  itself. We definitely should always write  $y(t)$  instead of just  $y$ , and we will sometimes, but it is traditional to be sloppy.

For example, if  $y$  happens to be 2000 at a particular time  $t$ , the rate of change of  $y$  is then  $.01(2000) = 20$ , and the units of this rate are dollars/year. From calculus we know that  $y$  is increasing whenever  $y'$  is positive, thus whenever  $y$  is positive. I hope your bank balance is positive!

PRACTICE: What do you estimate the balance will be, roughly, a year from now, if it is 2000 and is growing at 20 dollars/year?

This is not supposed to be a hard question. By the way, when I ask a question, don't cheat yourself by ignoring it. Think about it, and future things will be easier.

Later when  $y$  is, say, 5875.33, its rate of change will be  $.01(5875.33) = 58.7533$  which is much faster. We'll sometimes refer to  $y' = .01y$  as the banker's equation.

Do you begin to see how you can get useful information from a differential equation fairly easily, by just reading it carefully? One of the most important skills to learn about differential equations is how to read them. For example in the equation

$$y' = .01y - 10$$

there is a new negative influence on the rate of change, due to the  $-10$ . This  $-10$  could represent withdrawals from the account.

PRACTICE: What must be the units of the  $-10$ ?

Whether the resulting value of  $y'$  is actually negative depends on the current value of  $y$ . For example, if  $y = 100$  then  $y' = 1 - 10$  is negative, and  $y$  must be decreasing. If  $y = 1000$  then  $y' = 0$ , while if  $y = 2000$  then  $y'$  is positive and  $y$  is increasing. It seems that we ought to maintain some minimal balance. That is an example of “reading” a differential equation. As a result of this reading skill, you can perhaps recognize that the banker’s equation is very idealized: It does not account for deposits or changes in interest rate. It didn’t account for withdrawals until we appended the  $-10$ , but even that is an unrealistic continuous rate of withdrawal. You can think about how to modify the equation to include those things more realistically.

## 1.1 Slope Fields

It is significant that you can make graphs of the solutions sometimes. In the bank account problem we have already noticed that the larger  $y$  is, the greater the rate of increase. This can be displayed by sketching a “slope field” as in Figure 1.1. Slope fields are done as follows. First, the general form of an ordinary differential equation is

$$y' = f(y, t)$$

where  $y(t)$  is the unknown function, and  $f$  is given. To make a slope field for this equation, choose some points  $(y, t)$  and evaluate  $f$  there. According to the differential equation, these numbers must be equal to the derivative  $y'$ , which is the slope for the graph of the solution. These resulting values of  $y'$  are then plotted using small line segments to indicate the slopes. For example, at the point  $t = 6, y = 20$ , the equation  $y' = .01y$  says that the slope must be  $.01(20) = .2$ . So we go to this point on the graph and place a mark having this slope. Solution curves then must be tangent to the slope marks. This can be done by hand or computer, *without* solving the differential equation.

Note that we have included the cases  $y = 0$  and  $y < 0$  in the slope field even though they might not apply to your bank account.

PRACTICE: Try making a slope field for  $y' = y + t$ . To begin, what is the slope at  $(t, y) = (3, -3)$  if the solution  $y(t)$  goes through that point? What are all the points  $(t, y)$  where the slope is 0?

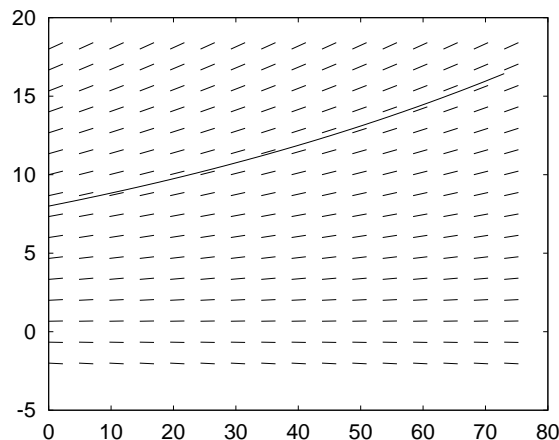

Figure 1: The slope field for  $y' = .01y$  as made by an `octave` script as on page 18. A solution starting from  $y(0) = 8$  is also shown.

There is also a way to explicitly solve the banker's equation. Assume we are looking for a positive solution. Then  $y$  is not zero so it is alright to divide the equation by  $y$ , getting

$$\frac{1}{y} \frac{dy}{dt} = .01$$

Then integrate, using the chain rule:

$$\ln(y) = .01t + c$$

where  $c$  is some constant. Then

$$y(t) = e^{.01t+c} = c_1 e^{.01t}$$

Here we have used a property of the exponential function, that  $e^{a+b} = e^a e^b$ , and set  $c_1 = e^c$ . The potential answer which we have found must now be checked by substituting it into the differential equation to make sure it really works. You ought to do this. Now. You will notice that the constant  $c_1$  can in fact be any constant, in spite of the fact that our derivation of it seemed to suggest that it be positive.

This is common with differential equations: It is not so important what methods you use; what is important is that you check to see whether you are right. Even *guessing* answers is a highly respected method! if you check them.

You might be skeptical about any bank account that grows exponentially. If so, good. It is clearly impossible for anything to grow exponentially forever. Perhaps it is reasonable for a limited time. The hope of applied mathematics is that

our models will be idealistic enough to solve while being realistic enough to be worthwhile.

The last point we want to make about this example concerns the constant  $c_1$ . What is the amount of money you originally deposited,  $y(0)$ ? Do you see that it is the same as  $c_1$ ? That is because  $y(0) = c_1 e^0$  and  $e^0 = 1$ . If your original deposit was 300 dollars then  $c_1 = 300$ . This value  $y(0)$  is called an “initial condition,” and serves to pick the solution we are interested in out from among all those which might be drawn in Figure 1.

EXAMPLE: Be sure you can do the following kind

$$\begin{aligned}x' &= -3x \\x(0) &= 5\end{aligned}$$

Like before, we get a solution  $x(t) = ce^{-3t}$ . Then  $x(0) = 5 = ce^0 = c$  so  $c = 5$  and the answer is

$$x(t) = 5e^{-3t}$$

Check it to be absolutely sure.

#### PROBLEMS

1. Make slope fields for  $x' = x$ ,  $x' = t$ ,  $x' = -x$ ,  $x' = -x + \cos t$ .
2. Sketch some solution curves onto the given slope field in Figure 2.
3. What general fact do you know from calculus about the graph of a function  $y$  if  $y' > 0$ ? Apply this fact to any solution of  $y' = y - y^3$ : consider cases where the values of  $y$  lie in each of the intervals  $(-\infty, -1)$ ,  $(-1, 0)$ ,  $(0, 1)$ , and  $(1, \infty)$ . For each interval, state whether  $y$  is increasing or decreasing.
4. (continuing 3.) If  $y' = y - y^3$  and  $y(0) = \frac{1}{2}$ , what do you think will be the  $\lim_{t \rightarrow \infty} y(t)$ ? Make a slope field if you're not sure.
5. Reconsider the banker's equation  $y' = .01y$ . If the interest rate is 3% at the beginning of the year and expected to rise linearly to 4% over the next two years, what would you replace .01 with in the equation? You are not asked to solve the equation.
6. In  $y' = .01y - 10$ , suppose the withdrawals are changed from \$10 per year continuously, to \$200 every other week. Do you think it would be alright to use a smooth function of the form  $a \cos bt$  to approximate the withdrawals? What would you take for  $a$  and  $b$ ?
7. A rectangular tank measures 2 meters east-west by 3 meters north-south and contains water of depth  $x(t)$  meters, where  $t$  is measured in seconds. One pump pours water in at the rate of  $.05 [m^3/\text{sec}]$  and a second variable pump draws water out at the rate of  $.07 + .02 \cos(\omega t) [m^3/\text{sec}]$ . The variable pump has period 1 hour. Set up a differential equation for the water depth, including the correct value of  $\omega$ .



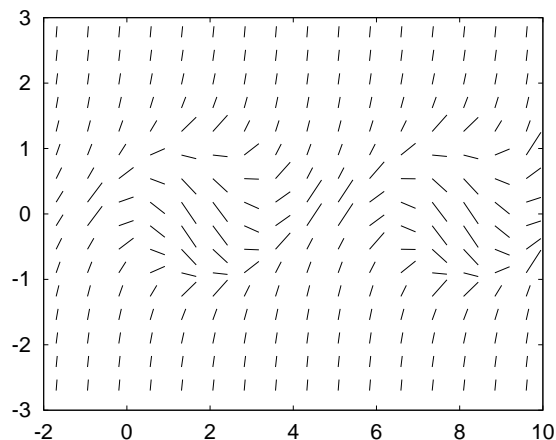

Figure 2: The slope field for Problem 2.

## 2 A Gallery of Differential Equations

TODAY: A gallery is a place to look and to get ideas, and to find out how other people view things.

Here is a list of differential equations, as a preview of things to come. Unlike the banker's equation  $y' = .01y$ , not all differential equations are about money. However, many of them are *conservation laws*, which track the changes in some quantity, like the banker's equation tracks your balance.

1.  $y' = .01(600 - y)$  This equation is a model for the heating of a pizza in a 600 degree oven. Of course the .01 is there for comparison with the banker's interest. The physical law involved is called "Newton's Law of Cooling" but it applies to heating also. We'll study it on page 17. This is a conservation law which tracks the exchange of heat energy between the pizza and the oven.
2. Newton's law of cooling is an ordinary differential equation, ODE. There are also partial differential equations, PDE, which means that the unknown functions depend on more than one variable. Then partial derivatives show up in the equation. One example is  $u_t = u_{xx}$  where the subscripts denote partial derivatives. This is a conservation law called the heat equation, and  $u(x, t)$  is the temperature at position  $x$  and time  $t$ , when heat is allowed to conduct only along the  $x$  axis, as through a wall or along a metal bar. It is

a more detailed study than Newton's law of cooling, and we will discuss it more starting on page 49.

3. Newton had other laws as well, one of them being the " $F = ma$ " law of inertia. You might have seen this in a physics class, but not realised that it is a differential equation. That is because it concerns the unknown position of a mass, and the second derivative  $a$ , of that position. In fact, the original differential equation, the very first one over 300 years ago, was made by Newton for the case in which  $F$  was the gravity force between the earth and moon, and  $m$  was the moon's mass. Before that, nobody knew what a differential equation was, and nobody knew that gravity had anything to do with the motion of the moon. (They thought gravity was what made their physics books heavy.)
4. Maxwell's equations for electric and magnetic fields in empty space are

$$E_t = \text{curl } B, \quad B_t = -\text{curl } E, \quad \text{div } E = 0, \quad \text{div } B = 0.$$

This is a system of first order partial differential equations in the six components of  $E$  and  $B$ . We won't discuss these except to see how they relate to the wave equation, see Problem 10.

5. There are many wave equations.  $u_{tt} = u_{xx}$  looks sort of like the heat conduction equation, but is very different because of the second time derivative. When it describes musical vibrations of a guitar string it is an instance of Newton's law of motion. When it describes light waves it is a consequence of Maxwell's equations. The equation for vibrations of a drum head is the two dimensional wave equation,  $u_{tt} = u_{xx} + u_{yy}$  that we discuss starting on page 69.

#### PROBLEMS

8. Newton's gravity law says that the force between a big mass at the origin of the  $x$  axis and a small mass at point  $x(t)$  is proportional to  $x^{-2}$ . How would you write the  $F = ma$  law for that as a differential equation?
9. What functions do you know about from calculus, that are equal to their second derivative? the negative of their second derivative?
10. Suppose the electric and magnetic fields are of the form  $E = (0, u, 0)$ ,  $B = (0, 0, v)$ . Use Maxwell's equations to show that  $u$  and  $v$  depend only on  $x$  and  $t$  and that  $u$  solves the wave equation  $u_{tt} = u_{xx}$ .

### 3 The Transport Equation

TODAY: A first order partial differential equation.

Here is a partial differential equation, sometimes called a transport equation, and sometimes called a wave equation.

$$\frac{\partial w}{\partial t} + 3\frac{\partial w}{\partial x} = 0$$

PRACTICE: We remind you that partial derivatives are the rates of change holding all but one variable fixed. For example

$$\frac{\partial}{\partial t} (x - y^2x + 2yt) = 2y, \quad \frac{\partial}{\partial x} (x - y^2x + 2yt) = 1 - y^2$$

What is the  $y$  partial?

Our PDE is abbreviated

$$w_t + 3w_x = 0$$

You can tell by the notation that  $w$  is to be interpreted as a function of both  $t$  and  $x$ . You can't tell what the equation is about. We will see that it can describe certain types of waves. There are many types of waves, such as water waves, electromagnetic waves, the wavelike motion of musical instrument strings, the invisible pressure waves of sound, the waveforms of alternating electric current, and others. This equation is a simple model.

PRACTICE: You know from calculus that increasing functions have positive derivatives. In Figure 3 a wave shape is indicated as a function of  $x$  at one particular time  $t$ . Focus on the steepest part of the wave. Is  $w_x$  positive there, or negative? Next, look at the transport equation. Is  $w_t$  positive there, or negative? Which way will the steep profile move next? Remember how important it is to read a differential equation.

#### 3.1 A Conservation Law

We'll derive the equation as one model for conservation of mass. You might feel that the derivation of the equation is harder than the solving of the equation.

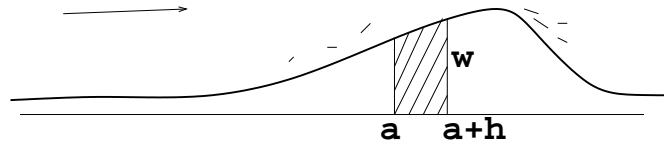

Figure 3: The wind blows sand along the surface. Some enters the segment  $(a, a+h)$  from the left, and some leaves at the right. The net difference causes changes in the height of the dune there.

We imagine that  $w$  represents the height of a sand dune which moves by the wind, along the  $x$  direction. The assumption is that the sand blows along the surface, crossing position  $(x, w(x, t))$  at a rate proportional to  $w$ . Thus taller areas encounter more wind-blown sand. The proportionality factor is taken to be 3, which has dimensions of velocity, like the wind.

The law of conservation of sand says that over each segment  $(a, a+h)$  you have

$$\frac{d}{dt} \int_a^{a+h} w(x, t) dx = 3w(a, t) - 3w(a+h, t)$$

That is the time rate of the total sand on the left side, and the sand flux on the right side. Divide by  $h$  and take the limit.

- PRACTICE: 1. Why is there a minus sign on the right hand term?  
 2. What do you know from the Fundamental Theorem of Calculus about

$$\frac{1}{h} \int_a^{a+h} f(x) dx?$$

The limit we need is the case in which  $f$  is  $w_t(x, t)$ .

We find that  $w_t(a, t) = -3w_x(a, t)$ . Of course  $a$  is arbitrary. That concludes the derivation.

### 3.2 Traveling Waves

When you first encounter PDE, it can appear, because of having more than one independent variable, that there is no reasonable place to start working. Do I try  $t$  first,  $x$ , or what? In this section we'll just explore a little. If we try something that doesn't help, then we try something else.

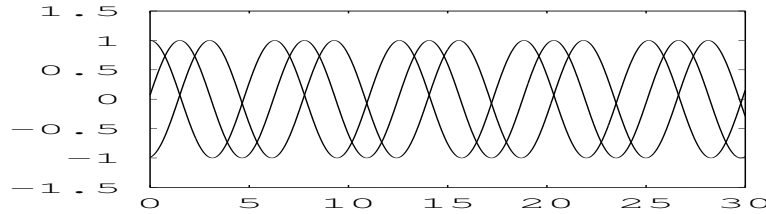

Figure 4: Graphs of  $\cos(x - 3t)$  at times  $t = 0, .5, 1$ . How fast is the wave moving?

PRACTICE: Find all solutions to our transport equation of the form

$$w(x, t) = ax + bt$$

In case that is not clear, it does not mean ‘derive  $ax + bt$  somehow’. It means substitute the hypothetical  $w(x, t) = ax + bt$  into the PDE and see whether there are any such solutions. What is required of  $a$  and  $b$ ?

Those practice solutions don’t look much like waves. Lets try something more wavey.

PRACTICE: Find all solutions to our transport equation of the form

$$w(x, t) = c \cos(ax + bt).$$

So far, we have seen a lot of solutions to our transport equation (if you did the practice problems). Here are a few of them:

$$w(x, t) = x - 3t$$

$$w(x, t) = -2.1x + 6.3t$$

$$w(x, t) = 40 \cos(5x - 15t)$$

$$w(x, t) = -\frac{2}{7} \cos(8x - 24t)$$

For comparison, that is a lot more variety than we found for the banker’s equation. Remember that the only solutions to the ODE  $y' = .01y$  are constant multiples of  $e^{.01t}$ . Now lets go out on a limb. Since our transport equation allows straight lines of all different slopes and cosines of all different frequencies and amplitudes, maybe it also allows other things too.

Try

$$w(x, t) = f(x - 3t)$$

where we won't specify the function  $f$  yet. Without specifying  $f$  any further, we can't find the derivatives we need in any literal sense, but can apply the chain rule anyway. The intention here is that  $f$  ought to be a function of one variable, say  $s$ , and that the number  $x - 3t$  is being inserted for that variable,  $s = x - 3t$ . The partial derivatives are computed using the chain rule, because we are composing  $f$  with the function  $x - 3t$  of two variables. The chain rule here looks like this:

$$w_t = \frac{\partial w}{\partial t} = \frac{df}{ds} \frac{\partial s}{\partial t} = -3f'(x - 3t)$$

PRACTICE: Figure out why  $w_x = f'(x - 3t)$ .

Setting those into the transport equation we get

$$w_t + 3w_x = -3f' + 3f' = 0$$

That is interesting. It means that any differentiable function  $f$  gives us a solution. Any dune shape is allowed. You see, it doesn't matter at all what  $f$  is, as long as it is some differentiable function.

Don't forget: differential equations are a model of the world. They are not the world itself. Real dunes cannot have just any shape  $f$  whatsoever. They are more specialized than our model.

PRACTICE: Check the case  $f(s) = 22 \sin(s) - 10 \sin(3s)$ . That is, verify that

$$w(x, t) = 22 \sin(x - 3t) - 10 \sin(3x - 9t)$$

is a solution to our wave equation.

#### PROBLEMS

11. Work all the practice items in this lecture if you have not done so yet.
12. Find a lot of solutions to the wave equation

$$y_t - 5y_x = 0$$

and tell which direction the waves move, and how fast.

13. Check that  $w(x, t) = \frac{1}{1 + (x - 3t)^2}$  is one solution to the equation  $w_t + 3w_x = 0$ .

14. What does the initial value  $w(x, 0)$  look like in problem 3, if you graph it as a function of  $x$ ?
15. Sketch the profile of the dune shapes  $w(x, 1)$  and  $w(x, 2)$  in problem 3. What is happening? Which way is the wind blowing? What is the velocity of the dune? Can you tell the velocity of the wind?
16. Solve  $u_t + u_x = 0$  if we also want to have the initial condition  $u(x, 0) = \frac{1}{5} \cos(2x) + \frac{1}{7} \sin(4x)$ . Sketch the wave shape for several times.

## 4 The Logistic Population Model

TODAY: The logistic equation is an improved model for population growth.

We have seen that the banker's equation  $y' = .01y$  has exponentially growing solutions. It also has a completely different interpretation from the bank account idea. Suppose you have a population containing about  $y(t)$  individuals. The word "about" is used because if  $y = 32.51$  then we will have to interpret how many individuals that is. Also the units could be, say, thousands of individuals, rather than just plain individuals. The population could be anything from people on earth, to deer in a certain forest, to bacteria in a certain Petrie dish. We can read this differential equation to say that the rate of change of the population is proportional to the number present. That perhaps captures some element of truth, yet we see right away that no population can grow exponentially forever. Sooner or later there will be a limit imposed by space, or food, or energy, or something.

### The Logistic Equation

Here is a modification to the banker's equation that overcomes the previous objection.

$$\frac{dy}{dt} = .01y(1 - y)$$

In order to understand why this avoids the exponential growth problem we must read the differential equation carefully. Remember that I said this is an important skill.

Here we go. You may rewrite the right-hand side as  $.01(y - y^2)$ . You know that when  $y$  is small,  $y^2$  is very small. Consequently the rate of change is still about  $.01y$  when  $y$  is small, and you will get exponential growth, approximately. After this goes on for a while, it is plausible that the  $y^2$  term will become important. In fact as  $y$  increases toward 1 (one thousand or whatever), the rate of change approaches 0. That is intended to limit the population.

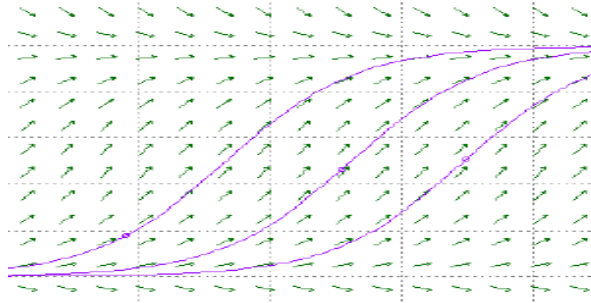

Figure 5: A slope field for the Logistic Equation. Note that solutions starting near 0 have about the same shape as exponentials until they get near  $a$ .

For simplicity we now dispense with the .01, and for flexibility introduce a parameter  $a$ , and consider the logistic equation

$$y' = y(a - y).$$

If we make a slope field for this equation we see something like Figure 5.

The solutions which begin with initial conditions between 0 and  $a$  evidently grow toward  $a$  as a limit. This in fact can be verified by finding an explicit formula for the solution. Proceeding much as we did for the bank account problem, first “separate” the variables

$$\frac{1}{ay - y^2} dy = dt$$

To make this easier to integrate, we’ll use a trick which was discovered by a *student* in this class, and multiply first by  $y^{-2}/y^{-2}$ . Then integrate

$$\int \frac{y^{-2}}{ay^{-1} - 1} dy = \int dt$$

$$-\frac{1}{a} \ln(ay^{-1} - 1) = t + c$$

The integral can be done without the trick, using partial fractions, but that is longer. Now solve for  $y(t)$

$$ay^{-1} - 1 = e^{-a(t+c)} = c_1 e^{-at}$$

$$y(t) = \frac{a}{1 + c_1 e^{-at}}$$

These manipulations would have to be done more carefully if we had not specified that we are interested in  $y$  values between 0 and  $a$ . For example, the  $\ln$  of a negative



number is not defined. However, we emphasize that the main point is to *check* any formulas found by such manipulations. So let's check it:

$$y' = \frac{a^2 c_1 e^{-at}}{(1 + c_1 e^{-at})^2}$$

We must compare this expression to

$$ay - y^2 = \frac{a^2}{1 + c_1 e^{-at}} - \frac{a^2}{(1 + c_1 e^{-at})^2} = a^2 \frac{(1 + c_1 e^{-at}) - 1}{(1 + c_1 e^{-at})^2}$$

You can see that this matches  $y'$ . Note that the value of  $c_1$  is not restricted to be positive, even though the derivation above may have required it. We have seen this kind of thing before, so checking is very important. The only restriction here occurs when the denominator of  $y$  is 0, which can occur if  $c_1$  is negative. If you stare long enough at  $y$  you will see that this does not happen if the initial condition is between 0 and  $a$ , and that it restricts the domain of definition of  $y$  if the initial conditions are outside of this interval. All this fits very well with the slope field above. In fact, there is only one solution to the equation which is not contained in our formula.

PRACTICE: Can you see what it is?

#### PROBLEMS

17. Suppose that we have a solution  $y(t)$  for the logistic equation  $y' = y(a - y)$ . Choose some time delay, say 3 time units to be specific, and set  $z(t) = y(t - 3)$ . Is  $z(t)$  also a solution to the logistic equation?

18. The three 'S'-shaped solution curves in Figure 5 all appear to be exactly the same shape. In view of Problem 17, are they?

19. Prof. Verhulst made the logistic model in the mid-1800s. The US census data from the years 1800, 1820, and 1840, show populations of about 5.3, 9.6, and 17 million. We'll need to choose some time scale  $t_1$  in our solution  $y(t) = a(1 + c_1 e^{-at})^{-1}$  so that  $t = 0$  means 1800,  $t = t_1$  means 1820, and  $t = 2t_1$  means 1840. Figure out  $c_1$ ,  $t_1$ , and  $a$  to match the historical data. WARNING: The arithmetic is very long. It helps if you use the fact that  $e^{-a \cdot 2t_1} = (e^{-at_1})^2$ . ANSWER:  $c_1 = 36.2$ ,  $t_1 = .0031$ , and  $a = 197$ .

20. Using the result of Problem 19, what population do you predict for the year 1920? The actual population in 1920 was 106 million. The Professor was pretty close wasn't he? He was probably surprised to predict a whole century.

21. Census data for 1810, 1820, and 1830 show populations of 7.2, 9.6, and 12.8 million. Trying those as in Problem 19, it turned out that I couldn't fit the numbers due to the numerical coincidence that

$$(7.2)(12.8) = (9.6)^2.$$

That is why I switched to the years in Problem 3. (This indicates that the fitting of real data to a model is nontrivial.) Show that exponential functions  $f(t) = ce^{kt}$  do have a related property:

$$f(t-b)f(t+b) = (f(t))^2.$$

But exponential functions don't solve the logistic model.

## 5 Existence and Uniqueness and Software

TODAY: We learn that some equations have unique solutions, some have too many, and some have none. Also an introduction to some of the available software.

If you are running an experiment you would like to think that the same results will follow from the same initial conditions each time you repeat the experiment. This makes us feel that our differential equations ought to have unique solutions.

On the other hand, it can happen that a differential equation has no solution at all, or a solution which is not defined for all time.

EXAMPLE: Consider  $x' = x^2$ . If  $x$  is never 0, multiply by  $x^{-2}$  to get

$$x^{-2}x' = 1.$$

Use the chain rule to recognize this as  $(-x^{-1})' = 1$ . Integrate to get  $-x^{-1} = t + c$ , so

$$x(t) = -\frac{1}{t+c}.$$

This function is not defined when  $t = -c$ .

In fact we should point out that the formula  $-\frac{1}{t+c}$  defines two functions, not one, the domains being  $(-\infty, -c)$  and  $(-c, \infty)$  respectively. The reason for this distinction is that the solution of a differential equation has to be differentiable, and therefore continuous.

We therefore are interested in the following general statement about what sorts of equations have solutions, and when they are unique, and how long, in time, these solutions last. It is called the Fundamental Existence Theorem.

We remind you that the partial derivative of a function of several variables is defined to mean that the derivative is constructed by holding all other variables constant. For example, if  $f(x, t) = x^2t - \cos(t)$  then  $\frac{\partial f}{\partial x} = 2xt$  and  $\frac{\partial f}{\partial t} = x^2 + \sin(t)$ .

**FUNDAMENTAL THEOREM** Consider an initial value problem of the form

$$\begin{aligned}x'(t) &= f(x, t) \\x(t_0) &= x_0\end{aligned}$$

where  $f$ ,  $t_0$ , and  $x_0$  are given. Suppose it is true that  $f$  and  $\frac{\partial f}{\partial x}$  are continuous functions of  $t$  and  $x$  in at least some small region containing the initial condition  $(x_0, t_0)$ . Then the conclusion is that there is a solution to the problem, it is defined at least for a small amount of time both before and after  $t_0$ , and there is only one such solution.

The example above,  $x' = x^2$ , is in the form specified:  $f(t, x) = x^2$  is continuous, and  $\frac{\partial f}{\partial x} = 2x$  is also continuous. Let's take the initial value to be  $x(0) = 2$ . The theorem applies, so we look at the conclusion: there is a solution defined for some interval of  $t$  around the initial time. Take  $c = -\frac{1}{2}$  in our solution formula, to get

$$x(t) = -\frac{1}{t - \frac{1}{2}}.$$

That has  $x(0) = 2$ . It is defined for  $-\infty < t < \frac{1}{2}$ , and blows up when  $t = 1/2$ . The theorem did not predict the blowup. If you were a scientist working on something which might blow up, you would be glad to be able to predict when or if the explosion will occur. But this requires a more detailed analysis in each case—there is no general theorem about it.

### Software

In spite of examples we have seen so far, it turns out that it is not possible to write down solution formulas for most differential equations. This means that we have to draw slope fields or go to the computer for approximate solutions. We soon will study how approximate solutions can be computed. Meanwhile we are going to introduce you to some of the available tools.

There are several software packages available to help your study of differential equations.

There are java applets available at

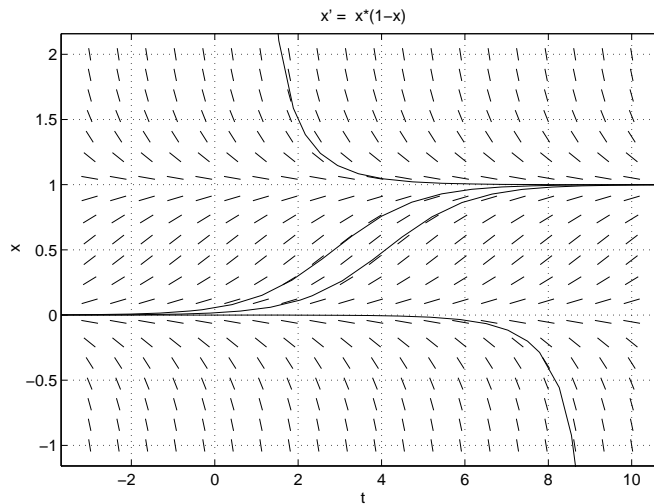

Figure 6: The slope field and several solutions for the Logistic Equation. Question: Do these curves really run into each other? Read the Fundamental Theorem again if you're not sure.

<http://math.rice.edu/~dfield/dfpp.html>

for a single ordinary differential equation,

<http://math.rice.edu/~pplane/pplane.html>

for a system of 2, and the rather primitive

<http://www.math.cornell.edu/~bterrell/de>

for a system of 1, 2, or 3. [At the time of writing, the dfield and pplane web page was under repair.] Probably the earliest user-friendly differential equation software was MacMath by John Hubbard. There are also java applets on partial differential equations. These are for the heat and wave equations in one or two space dimensions, and for the Laplace equation in two dimensions, available from

<http://www.math.cornell.edu/~bterrell>

The other approach is to do some programming in any of several available languages. These include matlab, its free counterpart octave available from

<http://www.octave.org>,

and the freeware program xpp. The script used to make several of the slope field

figures in these notes is listed in Figure 7. I ran it in `octave`. It approximates solutions using Euler's numerical method which is explained on page 24.

#### PROBLEMS

22. Find out how to download and use some of the programs mentioned in this lecture, try a few simple things, and read some of the online help which they contain.

23. Answer the question in the caption for Figure 6.

## 6 Newton's Law of Cooling

TODAY: The same mathematics can describe changing temperature of an object and balance on a loan.

The differential equation

$$x' = kx$$

says that the rate of change of  $x(t)$  is proportional to the value of  $x(t)$ . This is reasonable in some applications, such as when  $k$  represents the rate of interest on a savings account. The equation predicts exponential growth when  $k$  is positive, or decay when  $k$  is negative.

Newton's law of cooling is the statement that the exponential growth applies sometimes to the temperature of an object, provided that  $x$  is taken to mean the difference in temperature between the object and its surroundings. Suppose the object has temperature  $T(t)$  at time  $t$ . Then

$$x(t) = T(t) - E$$

where  $E$  is the environment temperature.

PRACTICE: If the object is hotter than the environment, will the object cool or heat? Is  $x'$  positive or negative?

In view of that practice (you did think about the practice right?) we will write the differential equation as  $x' = -kx$  where  $k$  is some positive number.

PRACTICE: Check that  $x' = -kx$  is equivalent to  $T' = -k(T - E)$ .

For example suppose we have placed a 100 degree pizza in a 600 degree oven. We let  $x(t)$  be the pizza temperature at time  $t$ , minus 600. This makes  $x$  negative, while  $x'$  is certainly positive because the pizza is heating up.

```

function dirf(x1,x2,t1,t2,x0)
    % make a direction field for x'= ef(x,t) in rectangle [t1,t2] by [x1,x2]
    % and compute a solution with initial value x(t1) = x0.

    tmarks = linspace(t1,t2,16); % 16 equally spaced t's for slope marks
    marklg = (t2-t1)/32;         % half as long each
    xlong = (x2-x1)/32;         % in case of steep slopes
    xmarks = linspace(x1,x2,16); % 16 equally spaced x's for slope marks
    teuler = linspace(t1,t2,100); % 100 t's for Euler method
    xeuler = zeros(1,100);      % 100 x's to be calculated
    tstep = (t2-t1)/100;

    % draw slope marks
    for i=1:16
        for j=1:16
            F = ef(xmarks(j),tmarks(i)); % the slope
            if abs(F)<1
                line([tmarks(i) tmarks(i)+marklg],...
                    [xmarks(j) xmarks(j)+marklg*F]);
            else
                line([tmarks(i) tmarks(i)+xlong/F],... % so mark isn't too long
                    [xmarks(j) xmarks(j)+xlong]);
            endif
        end
    end

    % draw Euler approximation
    xeuler(1) = x0;
    t = t1;
    for k=1:99
        xeuler(k+1) = xeuler(k)+tstep*ef(xeuler(k),t);
        t = t+tstep;
    end
    hold on
    plot(teuler,xeuler,"k")
    hold off

    print -deps -FHelvetica:20 "dirfig.eps"

    function val = ef(x,t) % the right hand side in x' = f(x,t)
        val = x.*x-sin(t); % change as needed

```

Figure 7: A program to draw slope fields (direction fields) in octave.

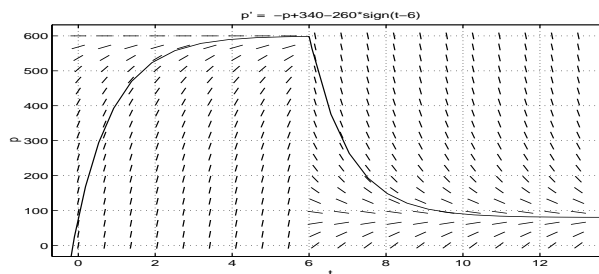

Figure 8: A pizza at temperature  $p(t)$  heats and then cools. ( $k = 1$  here.) To change the environment from 600 degrees to 80 degrees at time 6 the equation  $p' = -(p - E)$  was written as

$$p' = -p + a - b \operatorname{sign}(t - 6)$$

with  $a$  and  $b$  selected to achieve the 600 and 80.

PRACTICE: Check in this case (heating) too, it is correct to write  $T' = -k(T - E)$ , i.e., that both sides are positive.

Therefore Newton's law of cooling is also Newton's law of heating. The solution  $x(t) = Ce^{-kt}$ , and  $C = x(0) = 100 - 600$ . Equivalently the solution to

$$T' = -k(T - 600), \quad T(0) = 100$$

is the pizza temperature

$$T(t) = 600 - 500e^{-kt}.$$

We don't have any way to get  $k$  using the information given. It would suffice for example, to be told that after the pizza has been in the oven for 15 minutes, its temperature is 583 degrees. This says that  $583 = 600 - 500e^{-15k}$ . So we can solve for  $k$  and then answer any questions about temperature at other times.

In this model, we imagine that the environment is much larger than the object so that  $E$  doesn't change while  $T$  does change. But the environment temperature can change if we move the pizza from the oven to the 80 degree kitchen. A plot of the temperature history under such conditions is in Figure 8. The temperature is continuous when the move occurs at time  $t = 6$  but is not differentiable then.

A *first order linear* equation is of the form

$$x' + ax = b$$

where  $a$  and  $b$  might be functions of  $t$ . Newton's law of cooling  $T' = -k(T - E)$  and the exponential growth equation  $x' = kx$  are examples.

## 6.1 Investments

Our bank account equation  $y' = .01y$  can be made more realistic and interesting. Suppose we make withdrawals at a rate of \$3500 per year. This can be included in the equation as a negative influence on the rate of change.

$$y' = .01y - 3500$$

Again we see a first order linear equation. But the equation is good for more than an idealised bank account. Suppose you buy a car at 1% financing, paying \$3500 per year. Now loosen up your point of view and imagine what the bank sees. From the point of view of the bank, they just invested a certain amount in *you*, at 1% interest, and the balance decreases by “withdrawals” of about \$3500 per year.

So the same equation describes two apparently different kinds of investments.

EXAMPLE: A car is bought using the loan as described above. If the loan is to be paid off in 6 years, what price can we afford?

The price is  $y(0)$ . We need

$$y' = .01y - 3500 \quad \text{with } y(6) = 0.$$

As for Newton’s law of cooling, we can write it as  $y' = .01(y - 350\,000)$  and expect by analogy that  $y(t) = 350\,000 + c_1 e^{.01t}$ . Set  $t = 6$  to get  $0 = y(6) = 350\,000 + c_1 e^{.06}$ , so

$$c_1 = -350\,000 e^{-.06} = -329\,618.$$

This implies that the price is  $y(0) \doteq 350\,000 - 329\,618 \doteq 20\,382$ .

### PROBLEMS

24. Describe in whole sentences what the differential equation

$$y' = ky + \ell$$

could be used for. If someone in your family is interested but hasn’t taken the course, what background would you have to explain so he or she could read and understand the things you wrote?

25. This problem outlines a method for solving first order linear equations. Suppose we have the idea to multiply a first order linear equation  $x' + ax = b$  by a factor  $f$ , so that the result of the multiplication is  $(fx)' = fb$ , i.e., that the equation becomes recognizable as an instance of the product rule,

$$f'x + fx' = fb.$$

Show that for this plan to work, you will need to require that  $f' = af$ . In case  $a$  is constant, deduce that  $e^{at}$  will be a suitable choice for  $f$ . A function  $f$  used in this manner is called an *integrating factor*.



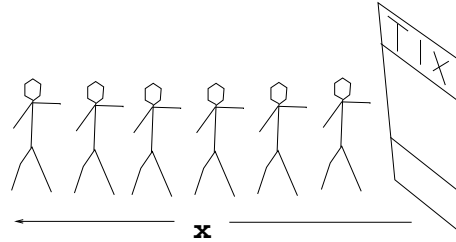

Figure 9: Here  $x(t)$  is the length of a line of people waiting to buy tickets. Is the rate of change proportional to the amount present? Does the ticket seller work twice as fast when the line is twice as long?

26. (continuing 25) In case  $a$  is a function of  $t$ , verify that  $e^{\int a dt}$  will be a suitable choice for  $f$ .

27. The temperature of an apple pie is recorded as a function of time. It begins in the oven at 450 degrees, and is moved to an 80 degree kitchen. Later it is moved to a 40 degree refrigerator, and finally back to the 80 degree kitchen. Make a sketch somewhat like Figure 8, which shows qualitatively the temperature history of the pie.

28. Newton's law of cooling looks like  $u' = -au$  when the surroundings are at temperature 0. This is sometimes replaced by the Stephan-Boltzmann law  $u' = -bu^4$ , if the heat is radiated away rather than conducted away. Suppose the constants  $a, b$  are adjusted so that the two rates are the same at some temperature, say 10 Kelvin. Which of these laws predicts faster cooling when  $u < 10$ ?  $u > 10$ ?

29. Sara's employer contributes \$3000 per year to a retirement fund, which earns 3% interest. Set up an initial value problem to model the balance in her fund, if it began with \$0 when she was hired. Use the result of Problem 25 to solve it. How much money will she have after 20 years?

30. Show that the change of variables  $x = \frac{1}{y}$  converts the logistic equation  $y' = .01(y - y^2)$  of Lecture 4 to the first order equation  $x' = -.01(x - 1)$ , and figure out a philosophy for why this might hold.

31. Answer the question in the caption of Figure 9.

## 7 Exact equations for Air and Steam

TODAY: An historically important "exact" differential equation happens to be first order linear too.

Some vector fields are gradients, some are not, and some differential equations are said to be *exact*. An "exact" differential  $mdx + ndy$  is one that can be written

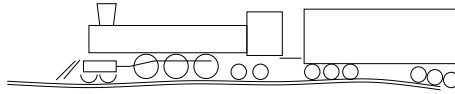

Figure 10: How fast can it go?

as  $df = f_x dx + f_y dy$  for some function  $f(x, y)$ . That is, it is associated with a gradient vector field  $\nabla f = f_x \vec{i} + f_y \vec{j}$ . [Associated in this sense: start at  $(x, y)$  where  $f(x, y)$  is the value. Take a step  $dx$  East, and a step  $dy$  North, then  $f$  changes approximately  $df$ . Instead of choosing  $dx$  and  $dy$  independently take your step  $dx\vec{i} + dy\vec{j}$  in the direction of  $\nabla f$  to get the largest possible increase in  $f$ . In fact  $df$  is the dot product of  $\nabla f$  with the step.] The differentials are often used in thermodynamics, while the gradient fields are used in many subjects, such as gravity. In this lecture we are just going to do one example.

It was in the early days of steam engines, when people first found out that there was a new invention on which they could travel at *25 miles per hour*. No human had ever gone nearly that fast except on a horse, or on ice skates. Can you imagine the thrill?

It was an outgrowth of the coal mining industry. Coal is fuel, but unfortunately for the miners, the mines tended to fill with water. A pump was made to fix this problem and it was driven by an engine which ran on, well, it ran on coal! But people being as they are, it wasn't long before somebody attached wheels to the engine and they started competing to see who could go fastest.

At about this time people noticed that every new train went faster than the last one. The natural question was whether there was any limit to the speed. So M. Carnot studied this and found that he could keep track of the temperature and pressure of the steam, but that neither of those was equal to the energy of the moving train. Eventually it was worked out that the heat energy added to the steam by the fuel was indeed related to the temperature and pressure. They called the new rule the first law of thermodynamics. It looked something like this, although the numbers I'm using here are for air, not steam:

$$\text{heat added} = 717 dT + 287 T \frac{dV}{V} \quad [\text{Joule/kg}]$$

is supposed to hold whenever a process occurs that makes a small change in the temperature  $T$  [Kelvin] and the specific volume  $V$  [ $m^3/\text{kg}$ ] of the gas. Here, the pressure comes in, again for air, through the ideal gas law  $P = 287\rho T$ ,  $V = 1/\rho$ . A main point discovered: that expression for heat added is *not* a differential of any

function of  $T$  and  $V$ . This was so important that they even made a special symbol for the heat added:  $dQ$  which survives to this day in some books.

PRACTICE: Using simpler numbers and variables, check that

$$7 dx + 2 \frac{x}{y} dy \neq df$$

for any function  $f(x, y)$ . If it were  $df = f_x dx + f_y dy$ , then you would have

$$7 = f_x \quad \text{and} \quad 2 \frac{x}{y} = f_y$$

See why that can't be true? What do you know about mixed partial derivatives,  $f_{xy}$  and  $f_{yx}$ ?

This relates to the gradient because an alternate way to express that is: For every function  $f$

$$7 \vec{i} + 2 \frac{x}{y} \vec{j} \neq \nabla f(x, y)$$

Anyway, the big disappointment to the steam engine builders was that the energy added in the process was not a differential, which meant that you could not make a table of values for how fast you are going to go, based only on temperature and pressure.

But, the big discovery was that if you divide the heat added by  $T$ , you can make a table of that.

PRACTICE:

$$7 \frac{dx}{x} + 2 \frac{dy}{y} = d(\text{something})$$

and so for air you also have

$$717 \frac{dT}{T} + 287 \frac{dV}{V} = \frac{\text{heat added}}{T} = d(\text{something})$$

The “something” is called *entropy*, denoted  $S$ , and for air,  $717 \frac{dT}{T} + 287 \frac{dV}{V} = dS$ . In Problem 32 you can figure out  $S$  from that. There are tables of the entropy of steam in the back of your thermodynamics book.

So what did Carnot come up with? Is there a limit to how fast the train can go? Well, he thought of an idealized engine cycle where for part of the time you have  $dT = 0$  and for the other part,  $dS = 0$ . Since it is possible to relate the  $V$  changes

to the mechanical work of the engine, that allows a computation to proceed. He worked out how fast that ideal train can go. You'll have to read about it in your thermo book.

#### PROBLEMS

32. Do the practice items if you haven't yet. Work out the entropy of air as a function of  $T$  and  $V$ .

33. Using the ideal gas law for air,  $P = 287 \rho T$ , work out the entropy of air as a function of  $T$  and  $P$ .

34. In the "isentropic" case, meaning entropy doesn't change, we can think of  $V$  as a function of  $T$  and write the equation

$$717 \frac{dT}{T} + 287 \frac{dV}{V} = 0$$

as a first order linear equation

$$\frac{dV}{dT} + \frac{717}{287} \frac{1}{T} V = 0.$$

Solve that. To simplify the numbers,  $717/287 = 2.5$ .

35. Redo Problem 34 thinking of  $T$  as a function of  $V$ .

36. Use the ideal gas law in the result of Problem 34 to show that  $P = k\rho^{1.4}$  for some constant  $k$ . We'll use this in Lecture 17.

## 8 Euler's Numerical Method

TODAY: A numerical method for solving differential equations either by hand or on the computer, several ways to run it, and how your calculator works.

Today we return to one of the first questions we asked. "If your bank balance  $y(t)$  is \$2000 now, and  $\frac{dy}{dt} = .01y$  so that its rate of change is \$20 per year now, about how much will you have in one year?" Hopefully you guess that \$2020 is a reasonable first approximation, and then realize that as soon as the balance grows even a little, the rate of change goes up too. The answer is therefore somewhat more than \$2020.

The reasoning which lead you to \$2020 can be formalised as follows. We consider

$$x' = f(x, t)$$

$$x(t_0) = x_0$$

Choose a “stepsize”  $h$  and look at the points  $t_1 = t_0 + h$ ,  $t_2 = t_0 + 2h$ , etc. We plan to calculate values  $x_n$  which are intended to approximate the true values of the solution  $x(t_n)$  at those times. The method relies on knowing the definition of the derivative

$$x'(t) = \lim_{h \rightarrow 0} \frac{x(t+h) - x(t)}{h}.$$

We make the approximation

$$x'(t_n) \doteq \frac{x_{n+1} - x_n}{h}$$

Then the differential equation is approximated by the difference equation

$$\frac{x_{n+1} - x_n}{h} = f(x_n, t_n)$$

EXAMPLE: Suppose the bank gives 2.8% interest. With  $h = 1$  it takes only one step to cover the first year. The bank account equation becomes

$$y' = .028y,$$

approximated by

$$\frac{y_{n+1} - y_n}{h} = .028y_n$$

or

$$y_{n+1} = y_n + .028hy_n$$

This leads to  $y_1 = y_0 + .028hy_0 = 1.028y_0 = 2056$ . For a better approximation we may take  $h = .2$ , but then 5 steps are required to reach the one-year mark. We calculate successively

$$y_1 = y_0 + .028hy_0 = 1.0056y_0 = 2011.200000$$

$$y_2 = y_1 + .028hy_1 = 1.0056y_1 = 2022.462720$$

$$y_3 = y_2 + .028hy_2 = 1.0056y_2 = 2033.788511$$

$$y_4 = y_3 + .028hy_3 = 1.0056y_3 = 2045.177726$$

$$y_5 = y_4 + .028hy_4 = 1.0056y_4 = 2056.630721$$

Look, you get more money if you calculate more accurately!

Here the bank has calculated interest 5 times during the year. “Continuously Compounded” interest means taking  $h$  close to 0, so that you are in the limiting situation of calculus.

We know the answer to this problem. It is  $y(1) = 2000e^{.028(1)} = 2056.791369\dots$ . Continuous compounding gets you the most money. Usually we do not have such formulas for solutions, and then we have to use this method or some other numerical method.

This method is called Euler’s method, in honour of Leonard Euler, a Swiss mathematician of the 18th century. He worked out many things, and in later life he was blind. Maybe you know that the “ $e$ ” in  $e = 2.718\dots$  does not stand for “exponential.” He also invented some things which go by other people’s names. So show some respect, and pronounce his name correctly, “oiler”.

Now we’ll do one for which the answer is not as easily known ahead of time. Assume that  $p(t)$  is the proportion of a population which carries but is not affected by a certain disease virus, initially 8%. The rate of change is influenced by two factors. First, each year about 5% of the carriers get sick, so are no longer counted in  $p$ . Second, the number of new carriers each year is about .02 of the population but varies a lot seasonally. The differential equation is

$$\begin{aligned} p' &= -.05p + .02(1 + \sin(2\pi t)) \\ p(0) &= .08 \end{aligned}$$

The solution in Figure 11 was computed using Euler’s method.

There are more sophisticated methods than Euler’s. One of them is built into `octave` under the name `lsode`. You can type `help lsode` in `octave` to get information on it, or try the example:

```
function xdot = ef(x,t)
xdot = -.05*x+.02*(1+sin(2*pi*t));
end;
t = linspace(0,10,200)';
x = lsode("ef",.08,t);
plot(t,x)
```

We will show one more example to convince you that these computations come close to things you already know. Look again at the simple equation  $x' = x$ , with  $x(0) = 1$ . You know the solution to this by now, right? Euler’s method with step  $h$  gives

$$x_{n+1} = x_n + hx_n$$

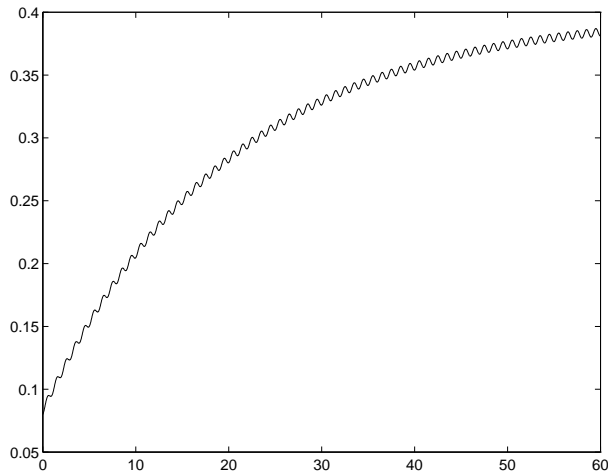

Figure 11: You can see the seasonal variation plainly, and there appears to be a trend to level off. This is a dangerous disease, apparently.

This implies that

$$x_1 = (1 + h)x_0 = 1 + h$$

$$x_2 = (1 + h)x_1 = (1 + h)^2$$

...

$$x_n = (1 + h)^n$$

Thus to get an approximation for  $x(1) = e$  in  $n$  steps, we put  $h = 1/n$  and receive

$$e \doteq \left(1 + \frac{1}{n}\right)^n$$

Let's see if this looks right. With  $n = 2$  we get  $(3/2)^2 = 9/4 = 2.25$ . With  $n = 6$  and some arithmetic we get  $(7/6)^6 \doteq 2.521626$ , and so forth. The point is that these calculations can be done without a scientific calculator. You can even use a grocery store calculator that only does  $+*$ , and use it to compute important things.

Did you ever wonder how your scientific calculator works? Sometimes people think all the answers are stored in there somewhere. But really it uses ideas and methods like the ones here to calculate many things based only on  $+*$ . Isn't that nice?

EXAMPLE: We'll estimate some cube roots by starting with a differential equation for  $x(t) = t^{1/3}$ . Then  $x(1) = 1$  and  $x'(t) = \frac{1}{3}t^{-2/3}$ . These give the differential equation

$$x' = \frac{1}{3x^2}$$

Then Euler's method says  $x_{n+1} = x_n + \frac{h}{3x_n^2}$ , and we will use  $x_0 = 1$ ,  $h = .1$ :

$$x_1 = 1 + \frac{.1}{3} = 1.033333\dots$$

Therefore  $(1.1)^{1/3} \doteq 1.0333$ .

$$x_2 = x_1 + \frac{h}{3x_1^2} \doteq 1.0645$$

Therefore  $(1.2)^{1/3} \doteq 1.0645$  etc. In fact,  $(1.0645)^3 = 1.206\dots$  For better accuracy,  $h$  can be decreased.

#### PROBLEMS

37. What does Euler's method give for  $\sqrt{2}$ , if you approximate it by setting  $x(t) = \sqrt{t}$  and solving

$$x' = \frac{1}{2x} \quad \text{with } x(1) = 1$$

Use 1, 2, and 4 steps, i.e.,  $h = 1, .5, .25$  respectively.

38. Solve

$$y' = (\cos y)^2 \quad \text{with } y(0) = 0$$

for  $0 \leq t \leq 3$  numerically.

39. Solve the differential equation in Problem 38 by separation of variables.

40. Compare your answers to Problems 38 and 39. Is it true that you just computed  $\tan^{-1}(3)$  using only  $+*/$  and cosine? Figure out a way to compute  $\tan^{-1}(3)$  using only  $+*/$ .

41. Solve the carrier equation  $p' = -.05p + .02(1 + \sin(2\pi t))$  using the integrating factor method. [The integral is pretty hard, but you can do it.] Predict from your solution, the proportion of the population at which the number of carriers "levels off" after a long time, remembering from Figure 11 that there will continue to be fluctuations about this value. Does your number seem to agree with the picture?

## 9 Spring-mass oscillations

TODAY: Forced and unforced frictionless oscillations. Natural frequency.



The prototype for today's subject is  $x'' = -x$ . You know the solutions to this already, though you may not realize it. Think about the functions and derivatives you know from calculus. In fact, here is a good method for any differential equation, not just this one. Make a list of the functions you know, starting with the very simplest. Your list might be

0  
1  
 $c$   
 $t$   
 $t^n$   
 $e^t$   
 $\cos(t)$   
...

Now run down the list trying things in the differential equation. In  $x'' = -x$  try 0. Well! what do you know? It works. The next few don't work. Then  $\cos(t)$  works. Also  $\sin(t)$  works. Frequently, as here, you don't need to use a very long list before finding something. As it happens,  $\cos(t)$  and  $\sin(t)$  are not the only solutions to  $x'' = -x$ . You wouldn't think of it right away, but  $2\cos(t) - 5\sin(t)$  also works, and in fact any *linear combination*  $c_1\cos(t) + c_2\sin(t)$  is a solution.

PRACTICE: Find similar solutions to  $x'' = -9x$ .

The equations  $x'' = cx$  occur frequently enough that you should know all their solutions.

PRACTICE: Find all solutions to  $x'' = 0$ . This is the case  $c = 0$  of  $x'' = cx$ .

Consider the equations

$$x'' + 3x = 0$$

$$y'' + 3y = \sin(2t)$$

The first one is called the homogeneous form of the second one, or the second is called a forced form of the first. Mechanically what they mean is as follows. Since we know the solutions to the first one (don't we?) are

$$x(t) = c_1 \cos \sqrt{3}t + c_2 \sin \sqrt{3}t$$

this first equation is about something vibrating or oscillating. It can be interpreted as a case of Newton's  $F = ma$  law, if you write it as  $-3x = 1x''$ . Here  $x$  is the position of a unit mass,  $x''$  is its acceleration, and there is a force  $-3x$  which

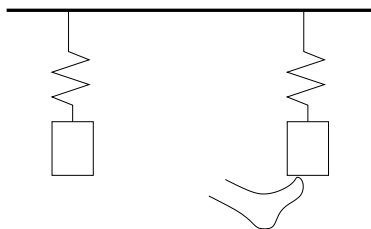

Figure 12: Unforced and forced spring–mass systems.

opposes the displacement  $x$ . We call this a “spring–mass” system. It can be drawn as in Figure 12, where  $x$  is measured up.

The  $-3x$  is interpreted as a spring force because it is in the direction opposite  $x$ : if you pull the spring 1.5 units up, then  $x = 1.5$  and the force is  $-4.5$ , or 4.5 units downward. This is also a system without friction, and without gravity, as we see from the fact that there are no other forces except for the spring force, and that the oscillation continues undiminished forever. Note that the “natural frequency” of this system is  $\frac{\sqrt{3}}{2\pi}$  cycles/second, in the sense that the period of  $x$  is  $\frac{2\pi}{\sqrt{3}}$ :

$$\begin{aligned} x\left(t + \frac{2\pi}{\sqrt{3}}\right) &= c_1 \cos\left(\sqrt{3}\left(t + \frac{2\pi}{\sqrt{3}}\right)\right) + c_2 \sin\left(\sqrt{3}\left(t + \frac{2\pi}{\sqrt{3}}\right)\right) \\ &= c_1 \cos\left(\sqrt{3}t + 2\pi\right) + c_2 \sin\left(\sqrt{3}t + 2\pi\right) = x(t). \end{aligned}$$

The forced equation involves an additional force, as you can see if you write it as  $-3y + \sin(2t) = 1y''$ . The picture in this case is like the right side of Figure 12.

Now we turn to solution methods for the forced equation. We are guided by the physics. What will happen with a system which wants to vibrate at a frequency of  $\frac{\sqrt{3}}{2\pi}$ , and somebody reaches in and shakes it at a frequency of  $\frac{2}{2\pi}$ ? Part of the motion could be at each of these frequencies. Let’s try that. Assume

$$y(t) = x(t) + A \sin(2t)$$

where  $x$  is the solution given above for the unforced equation. Then

$$y'' + 3y = x'' + 3x - 2^2 A \sin(2t) + 3A \sin(2t) = -A \sin(2t)$$

We want this to equal  $\sin(2t)$ , so  $A = -1$ . Notice how the terms involving  $x$  dropped out. Our solution becomes

$$y(t) = c_1 \cos(\sqrt{3}t) + c_2 \sin(\sqrt{3}t) - \sin(2t)$$

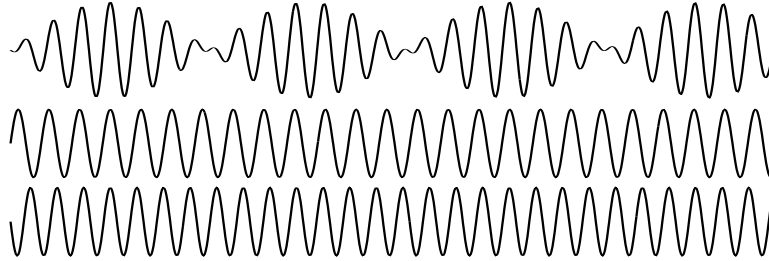

Figure 13: The top function is the sum of the other two!

One such solution,  $\sin(\sqrt{3}t) - \sin(2t)$ , is graphed in Figure 13, together with the individual terms  $\sin(\sqrt{3}t)$  and  $-\sin(2t)$ . In Problem 44 you can explore the patterns there.

## 9.1 Conservation laws and uniqueness

Sometimes a second order equation can be integrated once to yield a first order equation.

For example, let's pretend that we don't know how to solve the equation  $x'' = -x$ . You can try to integrate this equation with respect to  $t$ . Look what happens:

$$\int x'' dt = - \int x dt$$

PRACTICE: You can do the left side, getting  $x'$ , but what happens on the right?

Multiply the equation  $x'' = -x$  by  $x'$ . You get

$$x'x'' = -xx'$$

PRACTICE: See whether you can integrate it now.

Now  $xx'$  is the derivative of  $\frac{1}{2}(x)^2$ , and  $x'x''$  is the derivative of  $\frac{1}{2}(x')^2$ . So integrating, you get

$$\frac{1}{2}(x')^2 = c - \frac{1}{2}(x)^2$$

There is a physical interpretation for this first order equation, which is conservation of energy. Conservation of energy means the following:  $x$  is the position and  $x'$

the velocity of an oscillating particle. The energy is the sum of kinetic energy and potential energy. The kinetic energy  $\frac{1}{2}mv^2$  is  $\frac{1}{2}(x')^2$ , and the potential energy  $\frac{1}{2}kx^2$  is  $\frac{1}{2}x^2$  since here  $k$  and  $m$  are 1. So what is  $c$ ? It is the total energy of the oscillator. The energy is periodically transferred from to potential to kinetic and back.

Here is an example of the power of the conservation law.

UNIQUENESS THEOREM There is no other (real-valued) solution to  $x'' = -x$  than the ones you already know about.

You probably wondered whether anything besides the sine and cosine had that property. Of course there are the linear combinations of those. But maybe we just aren't smart enough to figure out others. The Theorem says no: that's all there are.

PROOF: Suppose the initial values are  $x(0) = a$  and  $x'(0) = b$ , and we write down the answer  $x(t)$  that we know how to do. Then suppose your friend claims there is a second answer to the problem, called  $y(t)$ . Set  $u(t) = x(t) - y(t)$  for the difference which we hope to prove is 0. Then  $u'' = -u$ . We know from the conservation law idea that then

$$\frac{1}{2}(u')^2 = c - \frac{1}{2}(u)^2$$

What is  $c$ ? The initial values of  $u$  are 0, so  $c = 0$ . That makes  $u$  identically 0. QED

PRACTICE: Do you see why  $c$  being zero makes  $u$  identically 0?

#### PROBLEMS

42. The solutions  $c_1 \cos t + c_2 \sin t$  of  $x'' = -x$  really are sinusoids: they can be written in the form

$$c \sin(t + d).$$

Use one of the addition formulas

$$\sin(a + b) = \sin(a) \cos(b) + \cos(a) \sin(b)$$

$$\cos(a + b) = \cos(a) \cos(b) - \sin(a) \sin(b)$$

to find equations connecting the unknown  $c$  and  $d$  with the known  $c_1$  and  $c_2$ . Note that here we were combining sinusoids having the same frequency.

43. Use the addition formulas for the sine and cosine to combine sinusoids of *different* frequencies: show that

$$c \sin(a + b) + d \sin(a - b) = (c + d) \sin(a) \cos(b) + (c - d) \cos(a) \sin(b).$$

44. Use the result of Problem 43 to find the period of the slow repetition (“beats”) in Figure 13.
45. Find a solution of  $x'' + 4x = \sin 3t$  of the form  $A \sin(3t)$ , and discuss what goes wrong when you try the same method on  $x'' + 4x = \sin 2t$ .
46. Find a conservation law for the equation  $x'' + x^3 = 0$ .
47. Do you think there are any conservation laws for  $x'' + x' + x = 0$ ?
48. *What's wrong with this?*  $x'' + 4x = 0$ ,  $x = \cos(2t) + \sin(2t) + C$

## 10 Applications of Complex Numbers

TODAY: A method for solving homogeneous linear equations introduces the exponential of complex numbers. We also use that to solve some forced equations.

### 10.1 Exponential and characteristic equation

The motivation for this method is that exponential functions have appeared several times in the equations which we have been able to solve. Trying  $x = e^{rt}$  in

$$ax'' + bx' + cx = 0$$

we find  $ar^2e^{rt} + bre^{rt} + ce^{rt} = (ar^2 + br + c)e^{rt}$  This will be zero only if

$$ar^2 + br + c = 0$$

since the exponential is never 0. This is called the *characteristic* equation. For example, the characteristic equation of  $x'' + 4x' - 3x = 0$  is  $r^2 + 4r - 3 = 0$ . See the similarity? We converted a differential equation to an algebraic equation that looks abstractly similar.

EXAMPLE:  $x'' + 4x' - 3x = 0$  has characteristic equation  $r^2 + 4r - 3 = 0$ . Using the quadratic formula, the roots are  $r = -2 \pm \sqrt{7}$ . So we have found two solutions  $x = e^{(-2-\sqrt{7})t}$  and  $x = e^{(-2+\sqrt{7})t}$ . Check that any linear combination

$$x(t) = c_1e^{(-2-\sqrt{7})t} + c_2e^{(-2+\sqrt{7})t}$$

is a solution too.

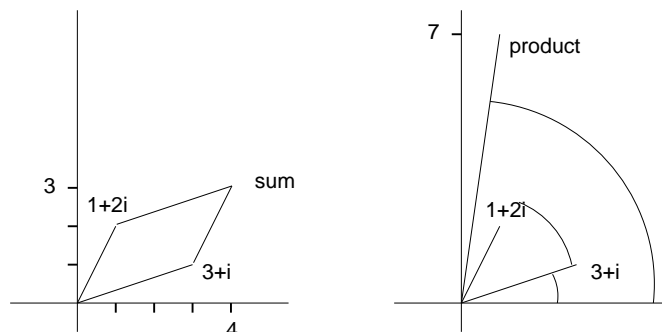

Figure 14: Addition of complex numbers is the same as for vectors. Multiplication adds the angles while multiplying the lengths. The left picture illustrates the sum of  $3 + i$  and  $1 + 2i$ , while the right illustrates the product.

EXAMPLE:  $x' + 3x = 0$  has characteristic equation  $r + 3 = 0$ , so a solution is  $e^{-3t}$ . Check that any multiple  $c_1 e^{-3t}$  is too.

PRACTICE:  $x'''' = 16x$  gives  $r^4 = 16$ . One root is  $r = 2$ , so one solution is  $e^{2t}$ . Are there others?

EXAMPLE: You already know  $x'' = -x$  very well, right? But our method gives the characteristic equation  $r^2 + 1 = 0$ . This does not have real solutions, so we'll have to work more to understand this one.

In view of that Example, let's talk about complex numbers.

**Complex numbers** Complex numbers are expressions of the form  $a + bi$  where  $a$  and  $b$  are real numbers. You add, subtract, and multiply them just the way you think you do, except that  $i^2 = -1$ . So for example,

$$(2.5 + 3i)^2 = 6.25 + 2(2.5)(3i) + 9i^2 = -3.25 + 15i$$

If you plot these points on a plane, plotting the point  $(x, y)$  for the complex number  $x + yi$ , you will see that the angle from the positive  $x$  axis to  $2.5 + 3i$  gets doubled when you square, and the length gets squared. Addition and multiplication are in fact both very geometric, as you can see from Figure 14.

PRACTICE: Use the geometric interpretation of multiplication in Figure 14 to find a square root of  $i$ .

Division of complex numbers is best accomplished by using this formula for reciprocals:

$$\frac{1}{a + bi} = \frac{a - bi}{a^2 + b^2}$$

**PRACTICE:** Verify that this reciprocal formula is correct, i.e., that if  $a$  and  $b$  are not both 0 then

$$\frac{a - bi}{a^2 + b^2}(a + bi) = 1.$$

**EXAMPLE:** Solve for  $a$ :

$$\frac{3}{i} - (2 + i)a = 7.$$

We find

$$\begin{aligned} a &= \frac{7 - \frac{3}{i}}{-(2 + i)} = -\frac{7 + 3i}{2 + i} \\ &= -(7 + 3i)\frac{2 - i}{2^2 + 1^2} = \frac{-14 - 6i + 7i + 3i^2}{5} = \frac{-17 + i}{5}. \end{aligned}$$

If  $z = a + bi$  and  $a$  and  $b$  are real, then the real and imaginary parts are  $\operatorname{re}(z) = a$  and  $\operatorname{im}(z) = b$ . (not  $bi$ .) Two complex numbers are equal by definition when the real and imaginary parts are equal.

**PRACTICE:** Check that  $1 + 0i = 0 + (-i)i$ . Why does this not contradict that last sentence?

In the example  $x'' = -x$  we found that we needed to understand

$$e^{\text{complex}}.$$

We define  $e^{(s+ti)} = e^s e^{ti}$  by analogy with known properties of real exponentials, but this still requires a definition of  $e^{ti}$ . We claim that the only reasonable choice is  $\cos(t) + i \sin(t)$ . The reason is as follows. The whole process of solving second order equations by the characteristic equation method depends on the formula

$$\frac{d(e^{rt})}{dt} = r e^{rt}$$

Let's require that this hold also when  $r = i$ . Writing  $e^{it} = f(t) + ig(t)$  this requires

$$f' + ig' = i(f + ig) = -g + if$$

so  $f' = -g$  and  $g' = f$ . These should be solved using the initial conditions  $e^0 = 1 = f(0) + ig(0)$ . These give  $f(0) = 1$ ,  $f'(0) = 0$  and  $f'' = -f$ . The only solution is  $f(t) = \cos(t)$  and  $g(t) = \sin(t)$ . Therefore our definition becomes

$$e^{s+ti} = e^s(\cos t + i \sin t).$$

Now it turns out that we actually get  $\frac{d(e^{rt})}{dt} = re^{rt}$  for all complex  $r$ . (See Problem 53.)

Now we can do more examples.

EXAMPLE:  $x'''' = 16x$  again. We find solutions  $e^{rt}$  if

$$r^4 = 16, \quad r^2 = 4, -4,$$

so

$$r = 2, -2, 2i, -2i.$$

These give real valued solutions  $x = e^{2t}$ ,  $x = e^{-2t}$ , and complex valued solutions  $x = e^{2it}$ ,  $x = e^{-2it}$ . The most general solution is

$$x(t) = c_1e^{2t} + c_2e^{-2t} + c_3e^{2it} + c_4e^{-2it}.$$

The last time you went into the lab, all the instruments were probably showing *real* numbers, weren't they? So it is common to rewrite our solutions in a real form. The following new idea is required: If  $x(t)$  is a complex solution to a linear differential equation with real coefficients then the real and imaginary parts of  $x$  are also solutions!

For example,  $e^{3it}$  is a solution to  $x'' = -9x$ . The real and imaginary parts are respectively  $\cos(3t)$  and  $\sin(3t)$ , and these are certainly solutions also.

To see why this works in general, suppose that  $x = u+iv$  solves  $ax''+bx'+cx = 0$ . This says that

$$a(u'' + iv'') + b(u' + iv') + c(u + iv) = (au'' + bu' + cu) + i(av'' + bv' + cv) = 0.$$

Assuming that  $a$ ,  $b$ ,  $c$ ,  $u$ , and  $v$  are all real, you can conclude that  $au'' + bu' + cu$  and  $av'' + bv' + cv$  are also 0.

PRACTICE: The same idea works for equations of any order. Try a first order one.

PRACTICE: The result does not work for the equation  $x'' + x^2 = 0$ . Why?



So let's rework the previous example. One solution to  $x'''' = 16x$  is  $e^{2it}$ . The real and imaginary parts are  $\cos(2t)$  and  $\sin(2t)$ . In fact we can write the previously given solution

$$x(t) = c_1 e^{2t} + c_2 e^{-2t} + c_3 e^{2it} + c_4 e^{-2it}$$

as

$$\begin{aligned} &= c_1 e^{2t} + c_2 e^{-2t} + c_3 (\cos(2t) + i \sin(2t)) + c_4 (\cos(2t) - i \sin(2t)) \\ &= c_1 e^{2t} + c_2 e^{-2t} + (c_3 + c_4) \cos(2t) + (c_3 - c_4) i \sin(2t) \\ &= c_1 e^{2t} + c_2 e^{-2t} + c_5 \cos(2t) + c_6 \sin(2t). \end{aligned}$$

EXAMPLE: Solve

$$y'' + 2y' + 2y = 0$$

The characteristic equation is  $r^2 + 2r + 2 = 0$ , so by the quadratic formula  $r = \frac{-2 \pm \sqrt{4-8}}{2} = -1 \pm i$ . One solution is  $e^{(-1+i)t} = e^{-t}(\cos(t) + i \sin(t))$ .

Taking the real and imaginary parts, the solution is

$$y(t) = c_1 e^{-t} \cos(t) + c_2 e^{-t} \sin(t)$$

Don't forget to check it.

#### PROBLEMS

49. Solve  $r^2 - 6r + 10 = 0$ ,  $r^3 - 6r^2 + 10r = 0$ , and  $r^2 - 6r - 10 = 0$ .

50. Solve  $y'' + 3y' + 4y = 0$ .

51. Find  $a$ , if  $a + \frac{1}{a} = 0$ ; if  $a + \frac{1}{a} = i$ .

52. Sketch the graphs of the functions  $e^{-t} \cos(t)$ ,  $e^{-t} \cos(3t)$ , and  $e^{-4t} \sin(3t)$ . Do these fit your idea of an oscillation with friction?

53. Use the definition

$$e^{(a+bi)t} = e^{at}(\cos(bt) + i \sin(bt))$$

to verify that

$$\frac{d(e^{rt})}{dt} = r e^{rt}$$

when  $r = a + bi$  is any complex number.

54. For each  $t$ ,  $e^{(1+i)t}$  is a complex number, which is a point in the plane. So as  $t$  varies, a curve is traced in the plane. Sketch it.

55. A polynomial  $r^2 + br + c = 0$  has roots  $r = -2 \pm i$ . Find  $b$  and  $c$ .

56. A characteristic equation  $r^2 + br + c = 0$  has roots  $r = -2 \pm i$ . What was the differential equation?

57. What's wrong with this?  $y'' + y^2 = 0$ ,  $r^2 + 1 = 0$ ,  $r = -1$ ,  $y = e^{-t} + c$ . There are at least 3 errors.

## 10.2 The Fundamental Theorem of Algebra

Think about this: A new number written  $i$  was invented to solve the equation  $x^2 + 1 = 0$ . Of course you have noticed that the people who invented it were not very happy about it: contrast “complex” and “imaginary” with “real” and “rational”. But soon the following theorem was discovered.

By introducing the new number  $i$ , not only can you solve  $x^2 + 1 = 0$ , but you can also solve at least in principle all these:

$$x^2 + 2 = 0, \quad x^3 - i = 0,$$

and even

$$x^6 - (3 - 2i)x^4 - x^3 + i\pi x - 39.1778i + 43.2 = 0.$$

FUNDAMENTAL THEOREM OF ALGEBRA Let

$$p(x) = a_0 + a_1x + a_2x^2 + \cdots + a_{n-1}x^{n-1} + x^n$$

be a polynomial of degree  $n > 0$  with any complex coefficients  $a_k$ . Then there are complex numbers  $r_1, r_2, \dots, r_n$  which are roots of  $p$  and  $p$  factors as

$$p(x) = (x - r_1)(x - r_2) \cdots (x - r_n)$$

As a practical matter, we can handle the cases  $a_0 + x$  and  $a_0 + a_1x + x^2$  easily. We all know the quadratic formula. There is a cubic formula that most people don't know for solving the  $n = 3$  case, and a quartic formula that hardly anybody knows for the  $n = 4$  case, which takes about a page to write. Then something interesting happens.

ABEL'S THEOREM Let  $n \geq 5$ . Suppose you figure out every formula that could ever be written in terms of the coefficients  $a_k$  and the operations of addition, subtraction, multiplication, division, and extraction of roots. Then none of those formulas give you the roots of the polynomial.

So: the roots exist, but if you need them then you will usually have to approximate them numerically.

PROBLEMS

58. In the Fundamental Theorem we took the coefficient of  $x^n$  to be 1 just for convenience. But if you don't do that the factorization must be written differently. For example,

$$-6 + x + x^2 = (x - 2)(x + 3)$$

is correct. Figure out the number  $c$  in the case

$$-30 + 5x + 5x^2 = c(x - 2)(x + 3)$$

59. How must the factorization be written in general if you don't assume the coefficient of  $x^n$  is 1?

60. You know that in the factorization  $-6 + x + x^2 = (x - 2)(x + 3)$  you have  $-6 = (-2)(3)$ . In general what is the product of the roots  $r_1 r_2 \cdots r_n$  in terms of parameters appearing in the Fundamental Theorem?

61. You know that in the factorization  $-6 + x + x^2 = (x - 2)(x + 3)$ , the  $x$  term comes from  $x = -2x + 3x$  when you multiply the right hand side. In general what is the sum of the roots  $r_1 + r_2 \cdots + r_n$  in terms of parameters appearing in the Fundamental Theorem?

### 10.3 A forced oscillator

Let's look at a spring and mass with friction and sinusoidal forcing.

Take  $F = ma$  in the form

$$-kx - cx' + \cos(\omega t) = mx''$$

for example

$$x'' + x' + x = \cos t.$$

We point out the following.

1.  $x$  is the real part of the solution to

$$z'' + z' + z = e^{it}$$

2. It is easy to find a solution  $z(t)$ .
3. Therefore a solution  $x$  can be found in two steps.

Let's see why these are true. 1. To say that  $x$  is the real part of  $z$  means that

$$z(t) = x(t) + iy(t)$$

for some real-valued  $y$ . Use the definition  $e^{it} = \cos t + i \sin t$  and differentiate  $z$  to get

$$z'' + z' + z = x'' + iy'' + x' + iy' + x + iy = \cos t + i \sin t.$$

The real parts must match:

$$x'' + x' + x = \cos t$$

(and the imaginary parts too:  $y'' + y' + y = \sin t$ ). 2. To find  $z$  we guess that the response will be proportional to the forcing,

$$z(t) = Ae^{it}.$$

Substituting,

$$z'' + z' + z = (i^2A + iA + A)e^{it} = iAe^{it}.$$

We need this to be  $e^{it}$ , so  $A = i^{-1} = -i$ . We have found

$$z(t) = -ie^{it} = -i(\cos t + i \sin t) = \sin t - i \cos t.$$

Since  $x$  is the real part, we found a solution

$$x(t) = \sin t.$$

PRACTICE: Check it.

Note: We made a guess and found a solution, but did not find all of them. We found, in a sense, the most important one. The reason is that all other solutions approach this one as time goes by. (See Problem 63.)

The force  $\cos t$  shakes the oscillator back and forth once every  $2\pi$  seconds. Now let's see what happens if we shake the oscillator at various frequencies. Remember that our definition

$$e^{i\theta} = \cos \theta + i \sin \theta$$

means: the point at angle  $\theta$  on the unit circle of complex numbers.

PRACTICE: Where on the unit circle will I find the number  $e^i$ ?

Please do *not* read any further until you understand that Practice problem, because I want you to understand what comes after it. Now  $e^{i\omega t} = \cos(\omega t) + i \sin(\omega t)$  runs around the unit circle at a constant speed which depends on  $\omega$ . So the real part oscillates between  $\pm 1$ , right?

Next, consider the function  $Ae^{i\omega t}$  where  $A$  is complex. Multiplication by  $A$  adds the angle of  $A$ , and rescales the size by  $|A|$ . So  $Ae^{i\omega t}$  runs around the circle of radius  $|A|$ .

PRACTICE: So the real part of  $Ae^{i\omega t}$  oscillates between what two real numbers?

Consider the equation

$$x'' + x' + x = \cos(\omega t)$$

which is like before except for the frequency parameter  $\omega$ . Do our two step method:

$$x = \operatorname{re} z$$

where  $z'' + z' + z = e^{i\omega t}$ . Try

$$z = Ae^{i\omega t}.$$

Then

$$z'' + z' + z = ((i\omega)^2 + i\omega + 1)Ae^{i\omega t} = e^{i\omega t}.$$

We need  $(-\omega^2 + i\omega + 1)A = 1$  or

$$A = \frac{1}{1 - \omega^2 + i\omega}.$$

If you did the Practice problem (eh?) then you know that  $x(t)$  oscillates between  $|A|$  and  $-|A|$ . This depends on  $\omega$ , so let's see how so:

$$|A| = \frac{1}{|1 - \omega^2 + i\omega|} = \frac{1}{\sqrt{(1 - \omega^2)^2 + \omega^2}}.$$

PRACTICE: A quick check on magnitudes of complex numbers: Is  $|3 + 4i|$  equal to  $\sqrt{3^2 + 4^2}$  or to  $\sqrt{3^2 - 4^2}$ ? According to Pythagoras, which one gives the correct distance to the origin?

Figure 15 shows the graph of the amplitude of  $x(t)$  as a function of  $\omega$ . This is called a *response curve*. It shows that the largest oscillations occur if the applied force has frequency about 1. There is very little response if you shake it fast.

PRACTICE: Try an experiment of that type, say with your keychain hanging from a rubber band. Jiggle the upper end of the rubber band fast and see whether the keys move very far.

#### PROBLEMS

62. Find a solution to  $y'' + y' + 3y = \sin(\omega t)$  in the form  $y(t) = \operatorname{im}(Ae^{i\omega t})$ .

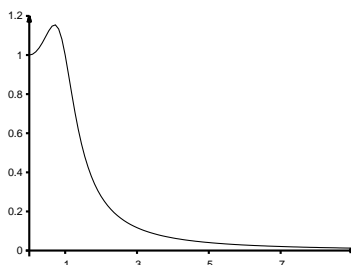

Figure 15: Graph of the amplitude (maximum over  $t$ ) of  $x(t)$  as a function of the forcing frequency  $\omega$ .

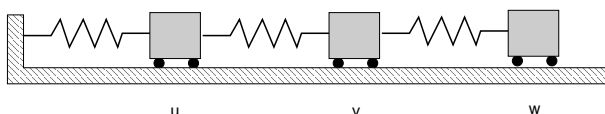

Figure 16: Three equal masses  $m$ , equal spring constants  $k$ . Their positions  $u$ ,  $v$ , and  $w$  are measured from the three equilibrium positions.

63. Check that if  $x_1$  and  $x_2$  are any two solutions of  $x'' + x' + x = \cos t$  then the difference  $x = x_1 - x_2$  satisfies  $x'' + x' + x = 0$ . Then use the characteristic equation to see that  $x(t)$  tends to 0 as  $t$  increases.

64. Plot the response curves for  $x'' + bx' + x = \cos(\omega t)$  for small and large values of  $b$ . Do they have the same shape?

## 11 Three masses oscillate

TODAY: Three masses, three frequencies, three modes of oscillation.

Newton's  $ma = F$  for the left mass in Figure 16 is

$$mu'' = -ku - k(u - v).$$

You won't have any trouble understanding the term  $-ku$  which is the force due to the left spring, but the  $-k(u - v)$  for the middle spring needs some thought.

PRACTICE: If  $u$  and  $v$  move the same distance to the right, what is  $u - v$  and what is the force on the left mass due to the middle spring?

PRACTICE: If  $v > u$  at some time, is the force to the right or left? Does this match the expression  $-k(u - v)$ ?

After thinking carefully about that, you will be able to write the Newton's laws for the middle and right masses:

$$mv'' = -k(v - u) - k(v - w),$$

$$mw'' = -k(w - v).$$

EXAMPLE: Suppose the masses are located at  $u = 1$ ,  $v = 2$ ,  $w = 4$ . What are the forces? The left spring is stretched by 1 unit, the middle one by  $2 - 1 = 1$ , the right by 2. So there is no net force on the left mass,  $k$  to the right on the middle mass, and  $-2k$ , that is  $2k$  to the left on the right mass.

To simplify the equations, take  $m = k = 1$ . Or, if you prefer, the time  $t$  can be rescaled by a factor of  $\sqrt{m/k}$ . The system becomes

$$u'' = -2u + v$$

$$v'' = -2v + u + w$$

$$w'' = -w + v.$$

Let's combine the 3 equations. From the  $u''$  equation we get  $v$  in terms of  $u$ :

$$v = u'' + 2u.$$

From the  $v''$  equation we get  $w = v'' + 2v - u$ . Substitute to get  $w$  in terms of  $u$ :

$$w = (u'' + 2u)'' + 2(u'' + 2u) - u = u'''' + 4u'' + 3u.$$

Substitute these expressions into the  $w''$  equation:

$$(u'''' + 4u'' + 3u)'' = (u'''' + 4u'' + 3u) + (u'' + 2u)$$

Combine terms to get a single equation for  $u$ :

$$u'''''' + 5u'''' + 6u'' + u = 0.$$

Figure 17 shows how complicated a solution  $u$  to this equation can be. Our job is to make sense of that!

Let's find simple solutions  $u$ . Try  $u(t) = e^{rt}$  as usual. We need

$$r^6 + 5r^4 + 6r^2 + 1 = 0.$$

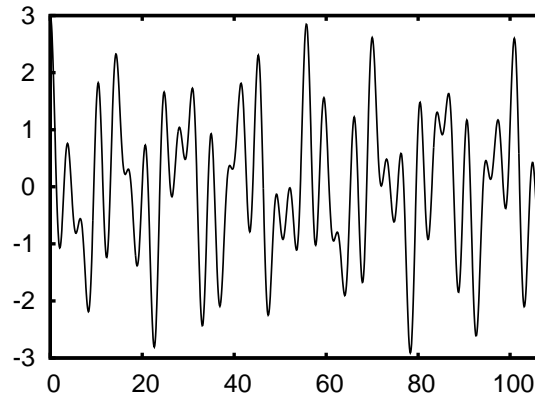

Figure 17: An example graph of  $u$ . Too complicated to understand (but less complicated than, say, a seismograph). It suggests that the smallest disturbances are equally spaced in time. That is a clue about the highest of the 3 frequencies.

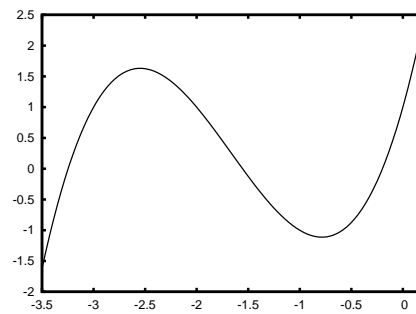

Figure 18: Graph of the cubic polynomial  $a^3 + 5a^2 + 6a + 1$ . The roots are approximately  $-3.2$ ,  $-1.6$ ,  $-0.3$ .

According to the fundamental theorem of algebra there will be 6 roots  $r$ . To locate them, notice there are no odd degree terms, so set  $r^2 = a$ . We need

$$a^3 + 5a^2 + 6a + 1 = 0.$$

This polynomial in the variable  $a$  is alternately  $1$ ,  $-1$ ,  $1$  when  $a = -2$ ,  $-1$ , and  $0$ , as we find by experimenting. Since the leading term is  $a^3$ , the values are negative for  $a$  large and negative and positive for  $a$  positive. According to the intermediate value theorem then there are roots between  $0$  and  $-1$ , between  $-1$  and  $-2$ , and less than  $-2$ . These are illustrated in Figure 18.

Since the three roots  $a = r^2$  are negative, the six roots  $r$  are pure imaginary, and



they are nearly

$$r = \pm 1.802i, \quad \pm 1.247i, \quad \pm .444i.$$

Therefore the solution  $u$  is a linear combination

$$u(t) = c_1 \cos(1.802t) + c_2 \sin(1.802t) \\ + c_3 \cos(1.247t) + c_4 \sin(1.247t) + c_5 \cos(.444t) + c_6 \sin(.444t)$$

and this corresponds to the complexity of Figure 17. What we want instead is to understand the individual modes. Take

$$u(t) = \cos(\omega t)$$

where  $\omega$  is any one of the three angular frequencies 1.802, 1.247, or .444. Use our previous substitutions to find

$$v(t) = u'' + 2u = (-\omega^2 + 2)u$$

and

$$w(t) = u'''' + 4u'' + 3u = (\omega^4 - 4\omega^2 + 3)u$$

What does that mean?  $w$  and  $v$  have different amplitude, and sometimes opposite directions from  $u$ , but the same frequency. See Figure 19.

$\omega$	1.802	1.247	.444
$-\omega^2 + 2$	-1.247	.444	1.802
$\omega^4 - 4\omega^2 + 3$	.555	-.802	2.250
$u$	$\cos(1.802t)$	$\cos(1.247t)$	$\cos(.444t)$
$v$	$-1.247u$	$.444u$	$1.802u$
$w$	$.555u$	$-.802u$	$2.250u$

The general solution consists of a combination of these three modes, which are hidden in Figure 17.

These complicated motions contain simpler motions at just 3 frequencies. This example relates to our later study of Fourier series: Fourier's project was to find all the frequencies hidden within functions.

#### PROBLEMS

65. If  $y_1$  is a solution to  $y'' + 3y' + 2y = 0$ , define  $y_2 = y_1'$ . Differentiate the differential equation to explain why  $y_2$  and  $y_1 + 8y_2$  are also solutions. Based on this idea, can you explain why  $u, v$ , and  $w$  all satisfy the *same* 6-th order equation?

66. The oscillation graphed in Figure 20 is a sum  $\cos(at) + \cos(bt) + .2\cos(ct)$ . Estimate the angular frequencies  $a, b$ , and  $c$ .

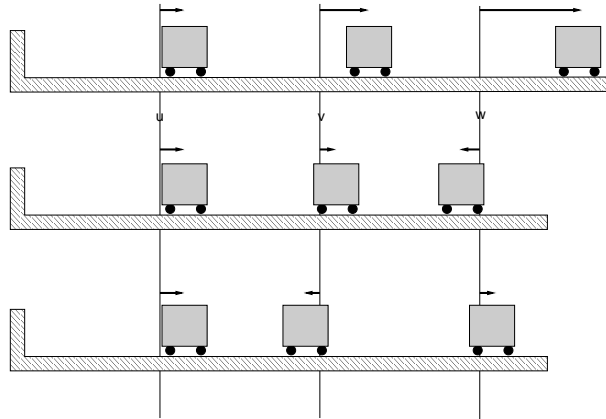

Figure 19: The three modes illustrated. At each time when  $u(t) = \cos(\omega t)$  is maximum,  $v$  and  $w$  are as shown.  $\omega = .444, 1.247, 1.802$  from top to bottom. Vertical lines mark the equilibrium positions.

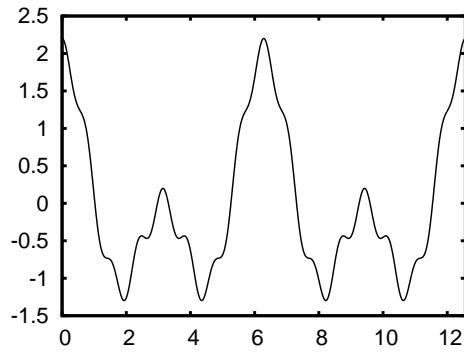

Figure 20: The graph in Problem 66. Remember 6 is approximately  $2\pi$ .

## 12 Boundary Value Problems

TODAY: A change from initial conditions. Boundary values. We find that we don't know everything about  $y'' = -y$  after all.

First you have to know what a boundary is. It is nearly the same thing in mathematics as on a map: the boundary of a cube consists of its six faces, the boundary of Puerto Rico is its shore line, the boundary of the interval  $[a, b]$  consists of the two points  $a$  and  $b$ . The concept of a boundary value problem is to require that some conditions hold at the boundary while a differential equation holds inside the set. Here is an example.

EXAMPLE:

$$\begin{aligned}y'' &= -y \\y(0) &= 0 \\y(2\pi) &= 0\end{aligned}$$

We are asked to solve a very familiar differential equation, but under very unfamiliar conditions. The function  $y$  is supposed to be 0 at 0 and  $\pi$ . The differential equation here has solutions  $y = A \cos(t) + B \sin(t)$ . We apply the first boundary condition, giving  $y(0) = 0 = A$ . So we must take  $A = 0$ . That was easy! Now apply the second boundary condition, giving  $y(2\pi) = 0 = B \sin(2\pi)$ . Well, it just so happens that the  $\sin(2\pi)$  is zero. So the second boundary condition is fulfilled no matter what  $B$  is. Answer:  $y(t) = B \sin(t)$ ,  $B$  arbitrary.

Notice how different this example was from our experience with initial conditions, that there were infinitely many solutions. Just the opposite thing can happen too:

EXAMPLE:

$$\begin{aligned}y'' &= -y \\y(0) &= 0 \\y(6) &= 0\end{aligned}$$

This seems close to the previous example since only  $2\pi$  has been changed to 6. This begins as before with  $A = 0$ . Then it just so happens that the  $\sin(6)$  is *not* zero. So unlike the previous case, we have to set  $B = 0$ . Answer:  $y(t) = 0$ . There is no other possibility.

What is a physical interpretation of these problems? We know that the equation  $y'' = -y$  describes an oscillator, a rock hanging from a Slinky, vibrating up and

down at frequency  $\frac{1}{2\pi}$ . The condition  $y(0) = 0$  says you want the rock at the origin at time 0. That just means you start the clock when it is there. Since the frequency of oscillation is  $\frac{1}{2\pi}$ , the rock will be back at the origin after  $2\pi$  seconds. The condition  $y(2\pi) = 0$  happens automatically. But if you require instead that  $y(6) = 0$ , then you are asking for the impossible. The rock takes  $2\pi = 6.283\dots$  seconds to get back, period. The only exception is the special function 0, signifying that the rock never moved at all. In that case it will certainly be back in 6 seconds, since it is there already. That is why there is no solution in the second case except for the 0 solution.

There is a tendency to use  $x$  as the independent variable when one is discussing boundary value problems rather than  $t$  because usually in practice it is position rather than time, in which one is interested. We'll do that in the next example. There is also the concept of *eigenvalue* in connection with boundary value problems.

EXAMPLE:

$$\begin{aligned}y'' &= -cy && \text{Finding } c \text{ is part of the problem too.} \\y(0) &= 0 \\y(\pi) &= 0\end{aligned}$$

The “eigenvalue” here is  $c$ . We will assume we are looking for positive values of  $c$ . Problem 67 will analyze the cases in which  $c$  might be 0 or negative. To solve this equation  $y'' = -cy$  we recognize that we are again looking at sines and cosines:  $y(x) = A \cos(\sqrt{c}x) + B \sin(\sqrt{c}x)$ , right? The boundary condition  $y(0) = 0 = A \cos(0) = A$  determines  $A = 0$  as before. Then we have to deal with the other boundary condition  $y(\pi) = 0 = B \sin(\sqrt{c}\pi)$ . Certainly if  $B = 0$  this is satisfied, and we have found a solution  $y(x) = 0$ . But we have another parameter  $c$  to play with, so let's not give up too easily. Question: Is it possible that

$$\sin(\sqrt{c}\pi) = 0$$

for some values of  $c$ ? If so,  $B$  can be anything and such  $c$  will be our eigenvalues. Well, what do you know about where sine is zero? Certainly  $\sin(0) = 0$  but if  $c = 0$  then we are back at  $y(x) = 0$  which is uninteresting by now. Where else is the sine zero? The sine is zero at  $\pi$ , for example. That gives  $\sqrt{c}\pi = \pi$ , or  $c = 1$ . There is a good solution to our problem!  $y(x) = B \sin(x)$ ,  $B$  arbitrary,  $c = 1$ . But there are other places where the sine is zero. For example  $\sin(2\pi) = 0$ . That gives  $\sqrt{c}\pi = 2\pi$ , or  $c = 4$ . So there is another solution  $y(x) = B \sin(2x)$ ,  $B$  arbitrary,  $c = 4$ . Also  $\sin(3\pi) = 0$ , giving a solution  $y(x) = B \sin(3x)$ ,  $B$  arbitrary,  $c = 9$ . In

general we have solutions

$$\begin{aligned}y(x) &= B \sin(nx) \quad B \text{ arbitrary} \\c &= n^2 \quad n = 1, 2, 3, \dots\end{aligned}$$

So the eigenvalues for this problem are 1, 4, 9, 16, 25, ...

PRACTICE: For which spring mass systems

$$my'' = -ky$$

with  $y(0) = 0$  is the mass located again at 0 after  $\pi$  seconds?

Eigenvalues are all around you. We'll mention them again in connection with string vibrations on page 68.

PROBLEMS

67. Find all the solutions to the  $c \leq 0$  cases of

$$\begin{aligned}y'' &= -cy \\y(0) &= 0 \\y(\pi) &= 0\end{aligned}$$

68. Find all the positive eigenvalues  $\lambda$  for the problem

$$\begin{aligned}y'' &= -\lambda y \\y(0) &= 0 \\y(6) &= 0\end{aligned}$$

## 13 The Conduction of Heat

TODAY: A derivation of the heat equation from physical principles. Two, in fact.

The heat equation looks like

$$u_t = au_{xx}.$$

It is an abbreviation for

$$\frac{\partial u}{\partial t}(x, t) = a \frac{\partial^2 u}{\partial x^2}(x, t)$$

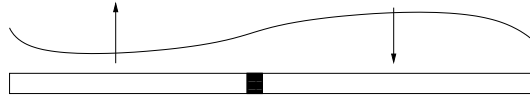

Figure 21: Temperature versus position along a metal bar. The arrows show the time dependence, according to the heat equation. On the left the temperature graph is concave up and the bar is warming, and on the right it is cooling. The shaded slab is used in the derivation.

It describes the temperature of an object in which heat energy is allowed to flow by conduction in the  $x$  direction. Heat can also move with a flowing fluid but that, known as convection, is not what this is about. Heat can also move as radiation, like the warming you feel near a fire even though the air itself may be cold. It is not about that either. It can describe the changing temperature along a metal bar or through a thick wall.

The equation concerns the temperature  $u(x, t)$  of a metal bar along which heat is conducted. You can imagine one end of the bar in the fire and the other in the blacksmith's hand, to emphasize that the temperature may change with time and with position along the bar. The number  $a$  is a physical constant which we will explain while we derive the heat equation.

Now let's read the heat equation carefully to see whether it makes any sense or not. Suppose you graph the temperature as a function of  $x$ , at a particular time. Maybe the graph is concave up as in Figure 21 on the left. What do you know from calculus about functions which are concave up? Isn't the second derivative positive? The heat equation contains the second derivative, and says that the more positive it is, the bigger the *time* derivative will be. What do you know from calculus about the first derivative being positive? Doesn't it mean that the function is increasing? So we have to imagine what that means, and conclude that the temperature must be rising at any point of the bar where the temperature graph is concave up. Similarly for the right side of Figure 21. If the temperature graph is concave down, the temperature must be decreasing with time. Does that seem correct? There is no hope of understanding partial differential equations unless you think about things such as that.

As you will see from our discussion, it is not necessary to think of a metal bar. It is also possible to think of the conduction of heat in the  $x$  direction, where this axis passes through a door or wall, or any similar situation in which heat energy flows in one dimension only. If you want to talk about heat flow along the surface of a sheet of metal you will have to use the two-dimensional heat equation

$$u_t = a(u_{xx} + u_{yy})$$

If you want to talk about heat flow throughout a solid block of metal or though still air, you use the three-dimensional heat equation

$$u_t = a(u_{xx} + u_{yy} + u_{zz})$$

Our plan is to derive the one-dimensional heat equation by showing what physical principles are behind it, and by using what you might call elementary mathematics, i.e. calculus. Later we will show a different derivation for the three-dimensional heat equation using the exact same physical principles, but more sophisticated mathematics, the Divergence Theorem.

Consider a little slab cut from the bar between coordinates  $x$  and  $x + \Delta x$ , and suppose the density of the bar is  $\rho$  mass per length. We are going to account for the heat energy contained within this little slab. We have

$$\begin{aligned}\Delta x &= \text{length of the slab} \\ \rho\Delta x &= \text{mass of the slab}\end{aligned}$$

**physical principle # 1:** There is something called specific heat,  $c$ , which reflects the experimental fact that a pound of wood and a pound of steel at the same temperature do not contain the same amount of heat energy. According to this principle we have

$$c\rho\Delta x = \text{the heat energy content of the slab}$$

**physical principle # 2:** Heat flows from hot to cold, and more specifically there is something called conductivity,  $k$ , which reflects the fact that copper conducts heat better than feathers do. According to this principle we have

$$\begin{aligned}-ku_x(x, t) &= \text{the rate heat enters the left side of the slab} \\ ku_x(x + \Delta x, t) &= \text{the rate heat enters the right side}\end{aligned}$$

These two principles give us two different expressions for the rate at which heat energy enters the slab. This is wonderful! Whenever you have two different expressions for the same thing, you are about to discover something important. Equate them:

$$(c\rho\Delta x)_t = ku_x(x + \Delta x, t) - ku_x(x, t).$$

Then divide by  $\Delta x$  to get

$$c\rho u_t = \frac{ku_x(x + \Delta x, t) - ku_x(x, t)}{\Delta x}.$$

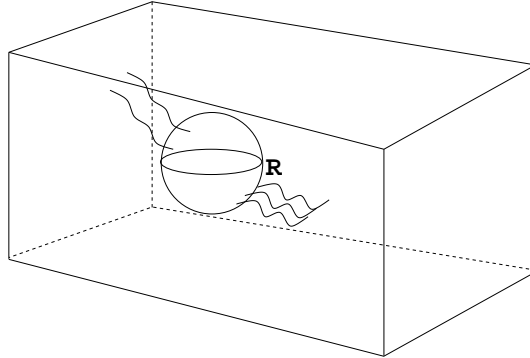

Figure 22: A region  $R$  inside the main block of material, with some heat energy flowing between  $R$  and the rest of the block. Energy conducts into  $R$  through its boundary surface  $S$ . There is no heat source or sink, chemical reaction etc., inside  $R$ . You can place  $R$  anywhere within the material.

Finally take the limit as  $\Delta x \rightarrow 0$  to get

$$c\rho u_t = k u_{xx}.$$

This gives the heat equation, and shows us that

$$a = \frac{k}{c\rho}.$$

A second derivation may be accomplished in three dimensions by using the divergence theorem. We imagine heat conduction in a solid block of some material, as in Figure 22. Fix any region  $R$  inside the solid and account for heat flow into  $R$ . The heat content is

$$\iiint_R c\rho u \, dV$$

and its rate of change is

$$\iiint_R c\rho u_t \, dV.$$

The rate of heat flow through the boundary surface  $S$  is

$$\iint_S k \vec{\nabla} u \cdot \vec{n} \, dA.$$

By the divergence theorem this last integral is equal to

$$\iiint_R \vec{\nabla} \cdot (k \vec{\nabla} u) \, dV.$$



Thus we have

$$\iiint_R c\rho u_t dV = \iiint_R \vec{\nabla} \cdot (k\vec{\nabla}u) dV.$$

Subtract to get

$$\iiint_R (c\rho u_t - k(u_{xx} + u_{yy} + u_{zz})) dV = 0.$$

for *all*  $R$ . Now if a function happens to integrate to zero it means nothing, except that here it is true for all  $R$ . This turns out to be enough (See Problem 72) to insure that the integrand is zero, and we get

$$c\rho u_t = k(u_{xx} + u_{yy} + u_{zz})$$

### 13.1 Walk the line

Let's see what happens when we allow heat to conduct along the whole number line. Remember a derivative is a limit of difference quotients, like

$$f'(a) = \lim_{h \rightarrow 0} \frac{f(a+h) - f(a)}{h}.$$

We'll use that for time derivative:

$$u_t(x, t) \approx \frac{u(x, t + \Delta t) - u(x, t)}{\Delta t}.$$

To simplify that, consider the arrangement in Figure 23. In that notation the time derivative approximation becomes

$$u_t|_{\text{point 2}} \approx \frac{u_{\text{new}} - u_2}{\Delta t}.$$

For the second space derivative  $u_{xx}$ , remember it is the  $x$  derivative of  $u_x$ . So we can do this:

$$\begin{aligned} u_{xx}(x, t) &\approx \frac{\frac{u_3 - u_2}{\Delta x} - \frac{u_2 - u_1}{\Delta x}}{\Delta x} \\ &= \frac{u_3 - 2u_2 + u_1}{(\Delta x)^2}. \end{aligned}$$

The heat equation becomes the statement

$$u_{\text{new}} = u_2 + \frac{\Delta t}{(\Delta x)^2} (u_3 - 2u_2 + u_1)$$

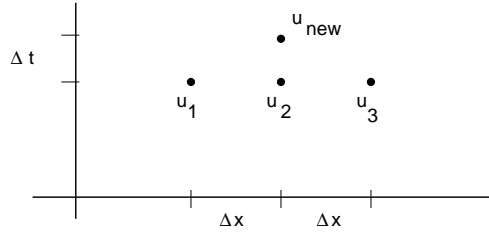

Figure 23: A stencil.

at each point within the  $(x, t)$  plane where  $x$  is in the material and  $t \geq 0$ . In fact the simplest case is when  $\frac{\Delta t}{(\Delta x)^2} = \frac{1}{2}$ . Then the  $u_2$ 's cancel and the whole thing simplifies to

$$u_{\text{new}} = \frac{1}{2}(u_3 + u_1)$$

We start with temperature  $u = 0$  everywhere along the line except  $u = 1$  at the origin.

PRACTICE: Take  $\Delta x = 1$ ,  $\Delta t = \frac{1}{2}$ ,  $u_1 = u(-1, 0) = 0$ ,  $u_2 = u(0, 0) = 1$ ,  $u_3 = u(1, 0) = 0$ . Figure out  $u_{\text{new}}$  which approximates  $u(0, .5)$ .

Then we use  $u_{\text{new}} = \frac{1}{2}(u_3 + u_1)$  to work forward in time (upward in Figures 23 and 24), like in the practice problem, and find the values shown in the table. In Problem 73 you fill values marked with asterisks (\*) at time  $5\Delta t$ .

In Figure 24 the first and last lines of the table have been plotted with dots connected to show the calculated temperatures at times 0 and  $6\Delta t$ .

Now: the numerical method leads, with a bit of wishful thinking, to the functions graphed at the bottom of the figure. The comparison suggests temperature functions of the form

$$u(x, t) = ae^{-bx^2}$$

where  $a$  and  $b$  could be functions of  $t$ . Let's try that! We find derivatives

$$u_x = -2xabe^{-bx^2}, \quad u_{xx} = -2abe^{-bx^2} + 4x^2ab^2e^{-bx^2}$$

and

$$u_t = a'e^{-bx^2} - ab'x^2e^{-b(t)x^2}.$$

$6\Delta t$	$\frac{1}{64}$	0	$\frac{6}{64}$	0	$\frac{15}{64}$	0	$\frac{20}{64}$	0	$\frac{15}{64}$	0	$\frac{6}{64}$	0	$\frac{1}{64}$
$5\Delta t$	0	*	0	*	0	*	0	*	0	*	0	*	0
$4\Delta t$	0	0	$\frac{1}{16}$	0	$\frac{4}{16}$	0	$\frac{6}{16}$	0	$\frac{4}{16}$	0	$\frac{1}{16}$	0	0
$3\Delta t$	0	0	0	$\frac{1}{8}$	0	$\frac{1}{8}$	0	$\frac{1}{8}$	0	$\frac{1}{8}$	0	0	0
$2\Delta t$	0	0	0	0	$\frac{1}{4}$	0	$\frac{2}{4}$	0	$\frac{1}{4}$	0	0	0	0
$\Delta t$	0	0	0	0	0	$\frac{1}{2}$	0	$\frac{1}{2}$	0	0	0	0	0
0	0	0	0	0	0	0	1	0	0	0	0	0	0
	$-6\Delta x$	$-5\Delta x$	$-4\Delta x$	$-3\Delta x$	$-2\Delta x$	$-\Delta x$	0	$\Delta x$	$2\Delta x$	$3\Delta x$	$4\Delta x$	$5\Delta x$	$6\Delta x$

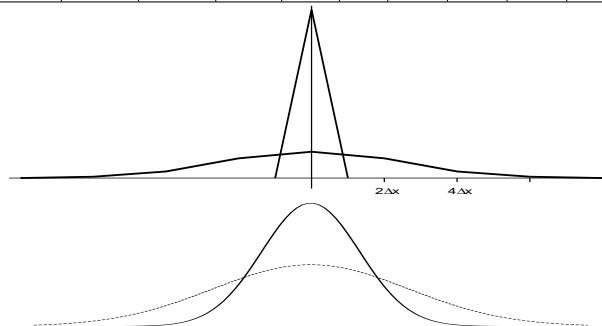

Figure 24: *Top:* A table of temperatures calculated using the stencil in Figure 23 with  $\Delta t = \frac{1}{2}(\Delta x)^2$ . *Center:* A sketch of the calculated temperatures  $u$  as function of position, at times 0 and  $6\Delta t$ , using values given in the first and last lines of the table. *Bottom:* The graphs of  $y = e^{-x^2/4}$  and  $y = \frac{1}{2}e^{-x^2/16}$ .

In order to have  $u_t = u_{xx}$ , we need

$$a' = -2ab, \quad -ab' = 4ab^2.$$

Since those are not familiar, let's see what part we can recognize. In the first equation we could solve for  $a(t)$  if  $b$  were constant or if we knew  $b$ . In the second equation we can cancel  $a$ , giving

$$-b' = 4b^2.$$

We can solve that one because it is separable. If  $b \neq 0$  divide to get

$$-b^{-2}b' = 4,$$

and integrate to get

$$b^{-1} = 4t + c.$$

Then  $b(t) = \frac{1}{4t + c}$ . Take the simplest case, where  $c = 0$ . Then

$$b(t) = \frac{1}{4t}, \quad a' = -\frac{1}{2t}a.$$

Now the  $a$  equation is separable too.

PRACTICE: Check that  $a(t) = \frac{1}{\sqrt{t}}$  is a solution to that last equation.

We have found

$$u(x, t) = \frac{1}{\sqrt{t}} e^{-x^2/4t}.$$

Of course it is only defined for  $t > 0$  because of the square root.

PRACTICE: Check derivatives again to verify that  $\frac{1}{\sqrt{t}} e^{-x^2/4t}$  is a solution to  $u_t = u_{xx}$ .

#### PROBLEMS

69. Suppose the same temperature distribution is present in two metal bars at a particular time, where the first bar has  $u_t = 3u_{xx}$  and the second has  $u_t = 4u_{xx}$ , due to different material. Which bar cools faster?

70. A new kind of physics is discovered on Mars. Their heat equation says  $u_t = au_{xx} - u$ . Do Mars bars cool faster or slower than Earth bars?

71. Amazingly enough, we have discovered that the heat equation used by the Klingons is different from either Earth or Mars. They have  $u_t = au_{xx} + u$ ,  $u_t = a(u_{xx} + u_{yy}) + u$  etc. Sometimes their pizza doesn't cool off at all. Why?

72. There is a way of thinking about continuous functions which is a little beyond the level of these notes, but you might be interested to hear it: Suppose continuous function  $f$  is not zero at some particular point  $a$ ,  $f(a) \neq 0$ . Maybe it is 0.266 there. Then you can take some other points  $x$  sufficiently close to  $a$  that  $f(x)$  is near 0.266, say  $f(x) > 0.200$ . This will hold for any point  $x$  in at least some small neighborhood of  $a$ . Knowing this, we take  $R$  in Figure 22 to be located right in that neighborhood. Then what can you say about  $\iiint_R f dV$ ? This shows that if these integrals are zero for all  $R$ , then  $f$  must be identically 0.

73. Use the numerical method  $u_{\text{new}} = \frac{1}{2}(u_3 + u_1)$  to fill in the missing (\*) values in the table in Figure 24.

## 14 Initial Boundary Value Problems for the Heat Equation

TODAY: The meaning of boundary values. Steady state solutions. Product solutions.

There are many, many solutions to the heat equation, by comparison with any ordinary differential equation. For example we found a solution

$$\frac{1}{\sqrt{t}}e^{-x^2/4t}.$$

More simply, all constants are solutions. A metal bar can certainly have a constant temperature. Another special class of solutions which are easy to find are the steady-state solutions, i.e. the ones which do not depend on the time. Everyday experience suggests that there are such cases; consider heat conduction through the wall of a refrigerator. The kitchen is at a constant temperature, the inside of the refrigerator is at a constant temperature, and there is a continual flow of heat into the refrigerator through the walls. To find such solutions analytically we assume that  $u$  is a function of  $x$  only. What happens to the heat equation then? We have  $u_t = 0$  and  $u_x = u'(x)$ , so the heat equation becomes  $u'' = 0$ . Integrating once we get  $u' = a$ . Integrating again gives  $u = ax + b$ . All straight lines are the graphs of steady-state temperature distributions. These straight-line solutions include the constant solutions.

So far we have not said much about boundary conditions or initial conditions. It is typical of partial differential equations that there are many possible choices of conditions, and it takes a lot of work to decide what the reasonable ones are. Let's say for now that we are interested in heat conduction along a bar of length  $l$  which is located in  $0 \leq x \leq l$ . Then one set of conditions which specifies a solvable problem is as follows. You may specify the temperature at the ends of the bar, and the initial temperature along the bar. For example here is one such problem.

$$\begin{aligned} u_t &= u_{xx} && \text{the heat equation} \\ u(0, t) &= 40 && \text{a boundary condition at the left end} \\ u(5, t) &= 60 && \text{boundary condition at right end; the length is 5} \\ u(x, 0) &= 40 + 4x && \text{the initial temperature} \end{aligned}$$

You may consider whether these conditions seem physically reasonable or not. The bar is going to have one end kept at 40 degrees, the other at 60 degrees, and the initial temperature is known. Should this kind of information be adequate to determine the future temperatures in the bar? This is a hard type of question in general, but in this case the answer turns out to be yes. In fact we can solve this particular problem with one of our steady-state solutions.

PRACTICE: Find the steady-state solution to that problem.

Next consider the problem

$$\begin{aligned}u_t &= u_{xx} \\u(0, t) &= 0 \\u(5, t) &= 0 \\u(x, 0) &= 40\end{aligned}$$

Here we have a bar of length 5 which begins uniformly at 40 degrees, and at time zero somebody presses ice cubes against both ends of the bar and holds them there forever. What should happen? In this case the initial condition does not match the boundary conditions, so the solution, if it exists, cannot be a steady-state solution. In this case, it is not possible to just quickly reason out whether the problem has any solution, or whether it might have more than one.

### 14.1 Insulation

There is another popular boundary condition known as insulation. What does insulation do? If you run out of fuel in the winter, your house cools, because energy conducts outward to the environment. It takes longer to cool, the better the insulation is. So we model insulation by the assumption that *no* energy passes through it. From our derivation of the heat equation, we know that the rate of energy conduction is a multiple of  $u_x$ . You might want to reread the derivation on this particular point. So: The boundary condition at an insulated end is  $u_x = 0$ .

Another way to think about insulation is like this: heat flows from hot to cold. So for heat to flow, there must be a temperature difference. On the other hand if  $u_x = 0$  somewhere, then the graph of temperature has slope 0, and microscopically there is no temperature difference for small position changes there.

Now what is the following problem about?

$$\begin{aligned}u_t &= u_{xx} \\u_x(0, t) &= 0 \\u(l, t) &= 60 \\u(x, 0) &= 40\end{aligned}$$

This is a bar of length  $l$ , insulated at the left end and held at 60 degrees at the right end. The initial temperature is 40 degrees all along its length.

## 14.2 Product Solutions

There is another class of solutions to the heat equation which can be found by a method we have used many times before. We try a solution of the form  $u = ce^{rt}$ .

This idea worked on ordinary differential equations. Now we need to allow  $c$  to be a function of  $x$ . Substituting into the heat equation  $u_t = au_{xx}$  gives  $rcce^{rt} = ac''e^{rt}$ . These will agree provided that  $ac'' = rc$ . We know how to solve  $ac'' = rc$ . It is a second order linear ordinary differential equation for  $c$ , and it is one of the easy kind with no  $c'$  term. To simplify it a little let's write  $r = -aw^2$ , then what we need is  $c'' = -w^2c$ . The solutions are  $c = A \sin(wx) + B \cos(wx)$ . Thus we have found many solutions to the heat equation of the form

$$u = (A \sin(wx) + B \cos(wx))e^{-aw^2t}.$$

EXAMPLE: Determine the values of  $w$  such that there is a product solution to

$$u_t = au_{xx}$$

having frozen boundary conditions

$$u(0, t) = u(\pi, t) = 0$$

We compute  $u(0, t) = Be^{-aw^2t}$  in the product solution above. This will be zero for all  $t$  only if  $B = 0$ . So far we have  $u = A \sin(wx)e^{-aw^2t}$ . Then we compute  $u(\pi, t) = A \sin(w\pi)e^{-aw^2t}$ . This will be zero for all  $t$  if we choose  $w\pi$  to be any of the zeros of the sine function. These make  $w = 1, 2, 3, \dots$ . We have found a list of solutions:

$$u_n(x, t) = A_n \sin(nx)e^{-an^2t}, \quad n = 1, 2, 3, \dots$$

Compare the solutions found in the Example to the eigenvalue problem discussed in Lecture 12.

### PROBLEMS

74. Describe in whole sentences what the following problem is about.

$$\begin{aligned}u_t &= u_{xx} \\u_x(0, t) &= 0 \\u_x(l, t) &= 0 \\u(x, 0) &= 400\end{aligned}$$

Determine whether there is a steady-state solution to this problem.

75. Describe what this problem is about.

$$\begin{aligned}u_t &= u_{xx} \\ u(0, t) &= 0 \\ u(l, t) &= 0 \\ u(x, 0) &= 400\end{aligned}$$

Determine whether there is a steady-state solution to this problem.

76. Find a product solution to

$$\begin{aligned}u_t &= 5u_{xx} \\ u(0, t) &= 0 \\ u(\pi, t) &= 0 \\ u(x, 0) &= 2 \sin(x)\end{aligned}$$

77. Determine whether there is a product solution to

$$\begin{aligned}u_t &= u_{xx} \\ u_x(0, t) &= 0 \\ u_x(\pi, t) &= 0 \\ u(x, 0) &= 3\end{aligned}$$

78. Suppose that  $u_1$  and  $u_2$  are solutions to

$$\begin{aligned}u_t &= u_{xx} \\ u(0, t) &= 0 \\ u(\pi, t) &= 0\end{aligned}$$

Note that no initial condition has been specified. Set  $s = u_1 + u_2$ . Is it true that  $s$  is also a solution to this system?

79. Find a solution to

$$\begin{aligned}u_t &= u_{xx} \\ u(0, t) &= 0 \\ u(\pi, t) &= 0 \\ u(x, 0) &= 3 \sin(x) + 5 \sin(2x)\end{aligned}$$

which is a sum of two product solutions. If you need help, look ahead to the next lecture, for which this problem is intended to be a preview.

80. Plot the graphs of the product functions  $u_n(x, t) = \sin(nx)e^{-an^2t}$  versus  $x$  for several values of  $t$ , for the cases  $n = 1$  and  $n = 2$ . Describe what is going on in your graphs, in terms of temperature in a metal bar.



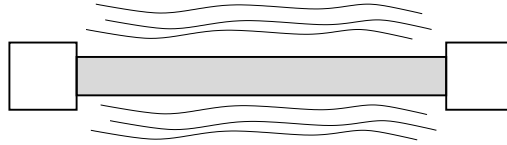

Figure 25: Ice cubes at the ends of the bar. There is insulation around the bar to make sure we have heat conduction in the  $x$  direction only.

81. In this problem

$$\begin{aligned} u_t &= u_{xx} \\ u(0, t) &= 0 \\ u(\pi, t) &= 0 \end{aligned}$$

suppose  $u(x, t) = e^{-at}y(x)$ , i.e. an exponential function of  $t$  times a function of  $x$ . What boundary value problem, of the type considered in Lecture 12 must  $y$  solve?

82. Let's relate the heat equation to Newton's law of cooling. Take the product solution

$$u = \sin(x)e^{-t}$$

to  $u_t = u_{xx}$ , and define the average temperature of the bar to be

$$T(t) = \frac{1}{\pi} \int_0^\pi u(x, t) dt.$$

Show that  $T' = -T$ , a version of Newton's law if you imagine the bar isolated in a frozen environment. More generally for any product solution  $u = \sin(nx)e^{-an^2t}$  show that the average temperature obeys  $T' = -an^2T$ . (But not all heat solutions obey Newton's law of cooling; see Problem 86 on page 64.)

### 14.3 Superposition

We are going to analyze a heat conduction problem which happens to be solvable using some of the product solutions found previously. Our emphasis is not on formulas, but on understanding what the solutions mean, and thinking about the extent to which this heat equation corresponds with our daily experience of temperature.

Consider the problem in which a metal bar with frozen ends has temperature initially as in Figure 26. We want to find out how this temperature changes as time goes by. What do you think will happen? We know from daily experience that heat flows from hot to cold, and in fact a quantitative version of that statement was a major part of our derivation of the heat equation. So probably the hot area to the left will supply energy to the cooler parts.

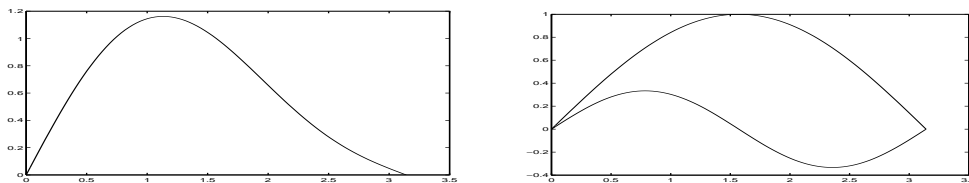

Figure 26: *Left*: Our initial conditions. Note the spot at which the bar is hottest. What do you think will happen to the hot spot as time goes by, i.e. will it cool off, will it move to the left, to the right, etc.? *Right*: The initial conditions are a sum of these two terms.

Our problem is as follows.

$$\begin{aligned}
 u_t &= u_{xx} \\
 u(0, t) &= 0 \\
 u(\pi, t) &= 0 \\
 u(x, 0) &= \sin(x) + \frac{1}{3} \sin(2x)
 \end{aligned}$$

Before attacking the problem analytically let's just read it carefully to see what it is about. That may be an obvious suggestion, but it is also a way to prevent ourselves from doing something idiotic. We see from the first line that we are solving the case of the heat equation in which the physical constant  $a$  has been set to 1 for convenience. We can't see what the domain is until we read the boundary conditions. The second two lines say that we are dealing with the ice cube case, where the bar ends are at 0 and  $\pi$  on the  $x$  axis and are kept frozen.

Finally the fourth line of the problem says that the initial temperature is the sum of two terms. Graphed separately, they look like the left part of Figure 26.

If you did problem 7 of Lecture 13, you may suspect why we have included the graph on the right side of Figure 26. Solutions to the heat equation may be added to produce new solutions. If you didn't do that problem yet, go do it now. In mathematics this is called linearity, and in physics it is sometimes called "superposition" to crystallize the idea that two or more things are going on at the same time and place.

Now we are ready to solve this problem. There are product solutions to the heat equation of the form  $u = A \sin(wx)e^{-aw^2t}$  for all values of  $w$ . Perhaps the ones we need are the cases of the sine function which appear in our initial conditions. Let's try that. Our candidates are

$$u_1(x, t) = A_1 \sin(x)e^{-t}$$

and

$$u_2(x, t) = A_2 \sin(2x)e^{-4t}$$

Now check to be sure that these solve the heat equation and the boundary conditions. Do that now. Does it work? Ok. Notice that it doesn't matter what the coefficients  $A_j$  are yet, *and* that the sum

$$u(x, t) = A_1 \sin(x)e^{-t} + A_2 \sin(2x)e^{-4t}$$

is also a solution to the heat equation with these frozen boundary conditions.

The next step is to attack the initial conditions. We need to compare

$$u(x, 0) = A_1 \sin(x)e^0 + A_2 \sin(2x)e^0$$

from our tentative solution, with the desired initial condition

$$u(x, 0) = \sin(x) + \frac{1}{3} \sin(2x)$$

Now the question is, can this be made to work? Well, yes, it is really not hard to see at this point, since we did all the hard work already. You just take  $A_1 = 1$  and  $A_2 = \frac{1}{3}$ . This makes the initial conditions work, and we have checked everything else. So we have a solution to our problem. It is

$$u(x, t) = \sin(x)e^{-t} + \frac{1}{3} \sin(2x)e^{-4t}.$$

The next step is to understand what this solution means and how it behaves as time goes by. The best way to do this is for you to sketch the graphs of the solution for various times, thinking about what happens to each of the two terms in the solution. If you do that yourself, and it is a good idea to do so, you should get something like the left side of Figure 27 for the individual terms, with the solution on the right side. If you study the solution formula and the pictures you will see how significant the  $n^2$  is in the time exponential part of the product solutions.

#### PROBLEMS

83. Think about what should happen to a metal bar which has an initial temperature distribution consisting of alternating hot, cold, hot, etc., in a lot of narrow bands along the bar. Think of a bar which is red-hot in six places and cooler in between. Do you think it will take very long for the temperature to change? Solve

$$\begin{aligned} u_t &= u_{xx} \\ u(0, t) &= 0 \\ u(\pi, t) &= 0 \\ u(x, 0) &= \sin(12x) \end{aligned}$$

and sketch the solution for  $t = 0, .3, .6$ .

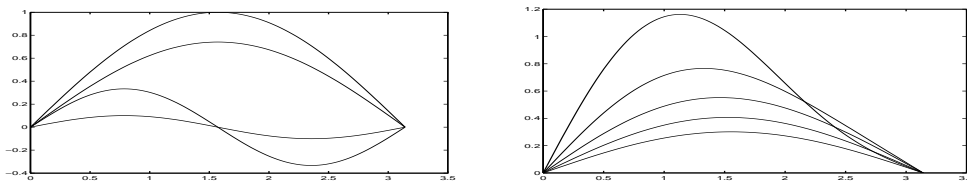

Figure 27: *Left:* The two terms in our solution, plotted for  $t = 0$  and  $t = .3$ . Notice that the term involving  $\sin(2x)$  has decayed a lot more than the  $\sin(x)$  term. Why is that? *Right:* The solution temperature at times  $t = 0, .3, .6, .9, 1.2$ . Why does the hot spot move toward the center?

84. Solve

$$\begin{aligned}
 u_t &= u_{xx} \\
 u(0, t) &= 0 \\
 u(\pi, t) &= 0 \\
 u(x, 0) &= \sin(x) + .5 \sin(3x) + .25 \sin(5x)
 \end{aligned}$$

Sketch the initial condition.

85. Solve

$$\begin{aligned}
 u_t &= u_{xx} \\
 u_x(0, t) &= 0 \\
 u_x(\pi, t) &= 0 \\
 u(x, 0) &= \cos(x) + .5 \cos(3x) + .25 \cos(5x)
 \end{aligned}$$

Note that the initial temperature satisfies the insulated boundary conditions.

86. Take  $u = \sin(x)e^{-t} + \sin(3x)e^{-9t}$  and define an average temperature of the bar to be

$$T(t) = \frac{1}{\pi} \int_0^\pi u(x, t) dx.$$

Show that Newton's law of cooling  $T' = -T$  is not quite true.

## 15 The Wave Equation

TODAY: Sums of traveling waves

We have now solved several heat conduction problems and are about to turn to another partial differential equation known as the wave equation. Notice that as we were working on the heat equation we solved a fairly large number of problems

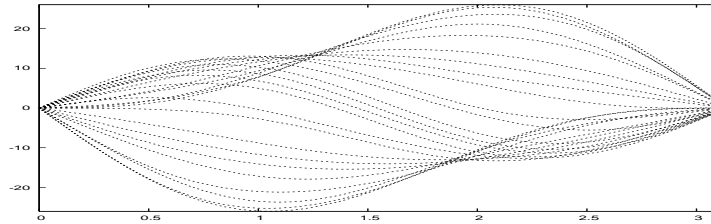

Figure 28: The one dimensional wave equation can describe vibrations of a string, shown here at several times.

distinguished from one another by boundary and initial conditions, while the equation itself never changed. This is typical of partial differential equations, that there are relatively few of them which are considered to be important, and the conditions can be changed to permit these few important equations to apply to many different settings. The wave equation can apply to many things also, such as the vibrations of a guitar string, but we are mainly going to talk about waves on an infinitely long string, the whole  $x$  axis. The reason for this choice is that guitar strings can be solved by methods similar to those we used for the heat equation, and we prefer to introduce new ideas here.

The wave equation is

$$\begin{aligned} u_{tt} &= c^2 u_{xx} \\ u_{tt} &= c^2 (u_{xx} + u_{yy}) \\ u_{tt} &= c^2 (u_{xx} + u_{yy} + u_{zz}) \end{aligned}$$

in one, two, or three dimensions, respectively. Note that it is second order with respect to the time, like Newton's law. In fact it *is* Newton's law in disguise, sometimes. We know that second order equations can describe oscillations, so that at least is reassuring. In one dimension  $u$  may represent the vertical position of a vibrating string. In two dimensions or three, the wave equation can represent vibrations of a drum head or of sound in the air, and other things like electromagnetic waves. It is a sound and light show all by itself.

Let's read the one dimensional equation again. If  $u$  is position, what is  $u_{tt}$ ? Think about it. Did you think about it yet? It is acceleration. Also when you draw the graph of  $u$  as a function of  $x$  as in Figure 28 what does  $u_{xx}$  represent? Just as for the heat equation, it is the curvature of the graph. The wave equation says that when the graph is concave up, the acceleration must be positive. Does that seem to fit with reality? Think about swinging a heavy jumprope. Better still, get a rope and try it. See whether you think the acceleration direction matches the curvature in this way.

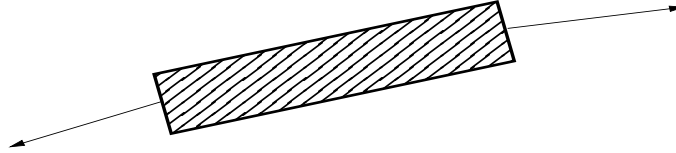

Figure 29: The tension in the string pulls at different angles on the two ends of any little piece of it, depending on the curvature.

The wave equation for a string may be derived as follows. We apply Newton's law to a bit of the string, accounting for vertical forces.

The tension  $T$  in the string has a vertical component. On the left it is approximately  $Tu_x(x, t)$  since the slope  $u_x$  is the tangent of the angle, which is near the sine of the angle if the angle is small. On the right it is  $Tu_x(x + \Delta x, t)$ . The difference of these must be the mass times the acceleration, so Newton's law becomes

$$Tu_x(x + \Delta x, t) - Tu_x(x, t) = \rho \Delta x u_{tt}$$

where  $\rho$  is the mass per length of the string. Dividing by  $\Delta x$  and taking the limit as  $\Delta x$  approaches 0 gives

$$\frac{T}{\rho} u_{xx} = u_{tt}$$

which is the wave equation with  $c^2 = \frac{T}{\rho}$ .

Now let's find some solutions to the wave equation, using our usual exponential method. We try

$$u = f(x)e^{rt}$$

in  $u_{tt} = c^2 u_{xx}$ . It becomes

$$r^2 f(x)e^{rt} = c^2 f''(x)e^{rt}.$$

Cancelling the time exponentials and setting  $r = ac$  gives  $f'' = a^2 f$ . Again an exponential trial gives solutions  $f(x) = e^{ax}$  and  $f(x) = e^{-ax}$ . We have found solutions

$$u = e^{\pm ax} e^{act}$$

where  $a$  could be any number, even complex. For example if  $a = 1$  we have found the solutions  $u = e^x e^{ct}$  and  $u = e^{-x} e^{ct}$ . To understand what these are, we graphed the second one in Figure 30.

These solutions certainly suggest that there are a lot of solutions which are functions of  $\pm x + ct$ , or equivalently of  $x \pm ct$ . Suppose you have a function

$$u(x, t) = g(x - ct) + h(x + ct)$$

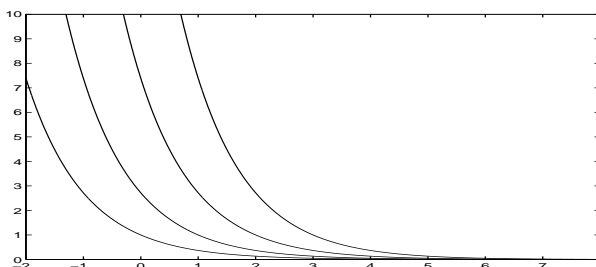

Figure 30: The wave  $u(x, t) = e^{-(x-ct)}$ , graphed for various times. Note that to keep the expression  $x - ct$  constant as  $t$  increases you have to increase  $x$  also, so this wave is moving to the right. It could make a surfer cry.

not necessarily built from exponentials at all. If you have read Lecture 3 you have seen waves traveling in one direction there. These go left or right. Taking derivatives by the chain rule we find

$$u_t = -cg'(x - ct) + ch'(x + ct)$$

$$u_{tt} = c^2g'' + c^2h''$$

$$u_x = g'(x - ct) + h'(x + ct)$$

$$u_{xx} = g'' + h''$$

Look what happened there. We got  $u_{tt} = c^2u_{xx}$  without assuming *anything* about  $g$  and  $h$  except that they be differentiable. Doesn't that mean you can add waves of nearly any shape moving left and right? Yes it does.

#### PROBLEMS

87. Show that  $\cos(x - 2t)$  and  $\frac{1}{(x + 2t)^2}$  are solutions to  $u_{tt} = c^2u_{xx}$  for some  $c$ . Find  $c$ . Graph these waves for  $t = 0, 1$ , and  $2$ .

88. The function  $\sin(x + t) + \sin(x - t)$  consists of 2 traveling waves and solves

$$\begin{aligned} u_{tt} &= u_{xx} \\ u(0, t) &= 0 \\ u(\pi, t) &= 0 \\ u(x, 0) &= 2\sin(x) \\ u_t(x, 0) &= 0 \end{aligned}$$

Sketch the two traveling waves, both separately and together, and try to see why the sum has the 0 boundary condition at  $x = 0$ , even though neither of the traveling waves does so separately.

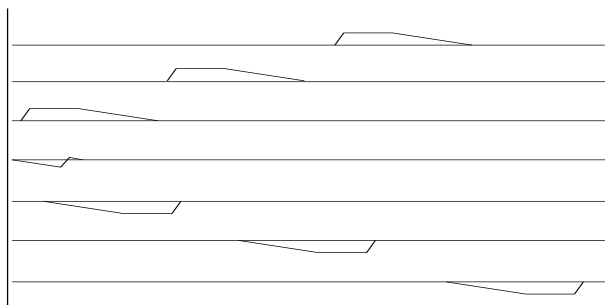

Figure 31: A wave traveling initially to the left is shown at six times,  $t$  increasing from top to bottom in the picture. It is reflected downward and reversed left-right when it bounces off a wall at the left side. Does this fit Problem 90 or Problem 91 better?

89. Use the addition formula for the sine to show that the function in problem 88 is equal to  $2 \sin(x) \cos(t)$ . It therefore represents a vibrating string having frequency  $\frac{1}{2\pi}$ . Then find a number  $k$  so that  $2 \sin(2x) \cos(kt)$  solves the problem:

$$\begin{aligned} u_{tt} &= u_{xx} \\ u(0, t) &= 0 \\ u(\pi, t) &= 0 \\ u(x, 0) &= 2 \sin(2x) \\ u_t(x, 0) &= 0 \end{aligned}$$

Sketch the motion for this case, and convince yourself that this vibration produces a sound one octave up from that of Problem 88, i.e. has twice the frequency.

Note that  $2 \sin(3x) \cos(3t)$  sounds a musical fifth above  $2 \sin(2x) \cos(2t)$ .

Also: the product solutions found in Problems 88 and 89 make use of the eigenfunctions  $y(x) = \sin(nx)$  that we previously found for the problem

$$\begin{aligned} y'' &= -\lambda y \\ y(0) &= 0 \\ y(\pi) &= 0 \end{aligned}$$

with eigenvalues  $\lambda = -n^2$ ,  $n = 1, 2, 3, \dots$

90. This problem is about using the wave equation to model an echo. Consider a function of the form  $u(x, t) = f(x + ct) + f(-(x - ct))$  where that is the same  $f$  traveling in both directions. Show that  $u$  satisfies the condition  $u_x(0, t) = 0$ . Think of sound waves moving in  $0 \leq x$  and a wall at the point  $x = 0$ . Sketch a graph of  $u$  for several times using a function  $f$  of your choice, and try to convince yourself that what you have sketched is a representation of waves bouncing off a wall.



91. Repeat Problem 90 for  $u(x, t) = f(x + ct) - f(-(x - ct))$ . This time you should get the boundary condition  $u(0, t) = 0$ , which involves a different kind of bouncing at the wall. Try to see it in your sketch. Which of Problems 90 or 91 is more like a string vibration, with the string tied down at the origin? Which one is more like water waves at the edge of a swimming pool?

92. *What's rong with this?* The function  $u(x, t) = \cos(t) \sin(x)$  couldn't be a solution to the wave equation because it isn't a traveling wave.

## 16 Application of Power Series: a Drum model

TODAY: We set up a model for the vibrations of a drum head. That requires a power series.

Our solutions so far have either been done numerically, or consisted of formulas involving familiar functions that can be found on any scientific calculator. For drum vibrations we need a new function, which is known, has a name, and you can google it, but there is no button for it on your calculator.

### The Drum

Our model of a drumhead has radius 1, and it only vibrates in circular symmetry. That means you can only hit it in the center, so to speak. Using polar coordinates, there is dependence on  $r$  and  $t$  but not on  $\theta$ . We write

$$u(r, t)$$

for the upward displacement of the drumhead out of its horizontal resting plane, and assume that  $u$  is small and that

$$u(1, t) = 0$$

since the edges of the head are pulled down against the rim of the drum.

We will assume that there is a tension  $T$  [ $N/m$ ] uniformly throughout the drumhead. In Problem 93 you can convince yourself that this is reasonable.

Now write Newton's  $F = ma$  law for vertical forces on any annular region of the drumhead. We take the annulus to have radius running from  $r$  to  $r + dr$ . In working out the forces due to the tension  $T$ , it is best if you have already worked on the wave equation for string vibrations. The reason is that while the forces here are quite similar to those acting on the string, the geometry here is a little more involved because of the curved shape of the annulus.

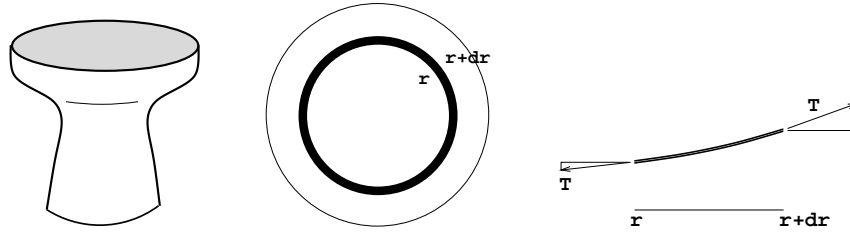

Figure 32: *Left:* A drum.  $u(r, t)$  is the vertical displacement of the drum head from equilibrium. *Center:* An annulus of drumhead material viewed from above. *Right:* A cut through the annular region, viewed on edge. The vertical displacement is greatly exaggerated. We're accounting for the vertical components of the tension forces.

The length of the inner curved edge of the annulus is  $2\pi r$ . There are forces directed inward all along that edge. We are interested only in the vertical resultant of those forces. That is  $T(2\pi r)$  times the sine of the small angle with the horizontal plane. The slope is  $u_r(r, t)$ . The slope  $u_r$  is nearly the same as the sine of the angle for small displacements. See Problem 95 if you aren't sure about that. Similarly for the outer edge.

The net force vertically is then

$$T(2\pi)(r + dr)u_r(r + dr, t) - T(2\pi r)u_r(r, t)$$

The acceleration of the annulus is  $u_{tt}$ . Mr. Newton says that we also need its mass. The mass of the segment is its area times its density  $\rho$  [ $\text{kg}/\text{m}^2$ ], or  $\rho(\pi(r + dr)^2 - \pi r^2)$ . By Newton then

$$T(2\pi)(r + dr)u_r(r + dr, t) - T(2\pi r)u_r(r, t) = \rho\pi(2r dr + (dr)^2)u_{tt}$$

Divide by  $dr$  and let  $dr$  tend to zero, giving  $\frac{\partial(Tru_r)}{\partial r} = \rho r u_{tt}$ . So our equation is

$$ru_{tt} = \frac{T}{\rho}(ru_r)_r \text{ or equivalently}$$

$$u_{tt} = \frac{T}{\rho} \left( u_{rr} + \frac{1}{r}u_r \right)$$

We will find some solutions to this having  $u(1, t) = 0$  at the rim of the drum. The solutions will be vibrations of our drum model, and hopefully will resemble vibrations of a real drum.

PRACTICE: Polar coordinates are awkward at the origin; for example the  $\frac{1}{r}$  coefficient of  $u_r$  is not defined there. What should the slope  $u_r(0, t)$  be at the center, so that the shape of the drumhead is smooth there?

## Separation of Variables

Maybe our wave equation has some product solutions of the form  $u(r, t) = R(r)T(t)$ . Since this is supposed to represent music, lets try

$$u(r, t) = R(r) \cos(\omega t)$$

or sine rather than cosine. Set that into the PDE to find

$$-\omega^2 \cos(\omega t)R = \frac{T}{\rho} \left( R'' + \frac{1}{r}R' \right) \cos(\omega t)$$

We need

$$R'' + \frac{1}{r}R' + \frac{\omega^2 \rho}{T}R = 0$$

For any such function we can find, there will be drum vibrations  $R(r) \cos(\omega t)$  and  $R(r) \sin(\omega t)$

In the next section we plan to find a nice solution  $R$ . However, it will be easier if we don't have to deal with the parameters  $\frac{\omega^2 \rho}{T}$  all the time. Let a new variable  $x = ar$  and choose  $a$  to clean up the  $R$  equation. Write  $R(r) = R(\frac{x}{a}) = f(x)$ . We have  $R'(r) = af'(x)$  and  $R''(r) = a^2 f''(x)$ . The DE for  $R$  becomes

$$a^2 f'' + \frac{a}{x}af' + \frac{\omega^2 \rho}{T}f = 0.$$

Of course we set  $a = \omega \sqrt{\frac{\rho}{T}}$ . Our new differential equation becomes

$$f'' + \frac{1}{x}f' + f = 0$$

## PROBLEMS

93. Imagine the tension forces on a small triangle of material located anywhere in the drumhead, as in Figure 33. Suppose a triangle with vertices  $(0, 0)$ ,  $(a, 0)$ , and  $(0, b)$  has a force applied uniformly along each edge, perpendicular to the edge, in the plane of the triangle, with magnitude  $T$  times that edgelength. Show that the triangle is in equilibrium, i.e. that the sum of forces on it is 0, assuming  $T$  is a constant.

94. Verify that none of the functions

$$e^{rx}, \quad \cos x, \quad \sin x, \quad ax^2 + bx + c$$

solve the equation  $f'' + \frac{1}{x}f' + f = 0$ .

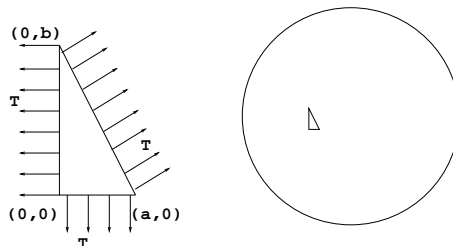
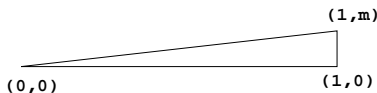

Figure 33: A triangle of the drumhead. See Problem 93.

95. Suppose a very acute triangle has vertices  $(0, 0)$ ,  $(1, 0)$ ,  $(1, m)$  so that the slope is  $m$ .



Convince yourself that  $m$  is the tangent of the acute angle exactly, and the sine of the acute angle is nearly equal to  $m$ . You could fiddle with the geometry, or try your calculator, or try the power series for the sine and cosine, or think of something else to try.

That is why we feel it is justified to replace the sine of the angles by the  $u_r$  values in our derivation. Of course, if it turns out that the model doesn't act like a real drum then we have to rethink this decision.

96. If you are not clear about the limit we found, try this. First tell what this limit is:

$$\lim_{h \rightarrow 0} \frac{f(x+h) - f(x)}{h}$$

Then how about

$$\lim_{h \rightarrow 0} \frac{(x+h)g(x+h) - xg(x)}{h}?$$

Finally the one we need

$$\lim_{dr \rightarrow 0} \frac{(r+dr)u_r(r+dr, t) - ru_r(r, t)}{dr}$$

### 16.1 A new Function for the Drum model, $J_0$

We learn a new function which might not be on your calculator, and use it to describe vibrations of the drum head.

So far we have derived a wave equation

$$u_{tt} = \frac{T}{\rho} \left( u_{rr} + \frac{1}{r} u_r \right)$$

for the displacement of our drumhead, and we know that we need to solve  $f'' + \frac{1}{x}f' + f = 0$ . Having such a function  $f$ , we will get many drum vibrations

$$u(r, t) = f\left(\omega\sqrt{\frac{\rho}{T}}r\right) \cos(\omega t)$$

### A new function, $J_0$

Try a power series

$$f(x) = f_0 + f_2x^2 + f_4x^4 + \dots$$

If you did the practice item on page 70, you know that we don't want a term  $f_1x$ . We are guessing that we don't need any of the odd degree terms. To keep things as clean as possible let's also take  $f_0 = 1$ . We can rescale things later as needed. We have

$$\begin{aligned} f'' + \frac{1}{x}f' + f &= \left(2f_2 + 4 \cdot 3f_4x^2 + 6 \cdot 5f_6x^4 + 8 \cdot 7f_8x^6 + \dots\right) \\ &+ \left(2f_2 + 4f_4x^2 + 6f_6x^4 + 8f_8x^6 + \dots\right) + \left(1 + f_2x^2 + f_4x^4 + f_6x^6 + \dots\right) \\ &= (4f_2 + 1) + (4 \cdot 4f_4 + f_2)x^2 + (6 \cdot 6f_6 + f_4)x^4 + (8 \cdot 8f_8 + f_6)x^6 + \dots \end{aligned}$$

For that to be identically 0, we need all the coefficients to be 0, so

$$f_2 = -\frac{1}{2^2}, \quad f_4 = -\frac{f_2}{4^2} = \frac{1}{2^24^2}, \quad f_6 = -\frac{f_4}{6^2} = -\frac{1}{2^24^26^2}, \quad f_8 = \frac{1}{2^24^26^28^2},$$

etc. So

$$f(x) = 1 - \frac{x^2}{2^2} + \frac{x^4}{2^24^2} - \frac{x^6}{2^24^26^2} + \frac{x^8}{2^24^26^28^2} - \dots$$

Isn't that a beautiful series?

This function is sufficiently useful that it has a name, even though you won't find it on every calculator. It is called the Bessel function  $J_0$ . So  $f(x) = J_0(x)$  or, if we need a multiple of that,  $f(x) = f_0J_0(x)$  for some constant  $f_0$ . We need to know what this function is like, to see whether it gives us plausible drumhead vibrations

$$u(r, t) = f_0J_0\left(\omega\sqrt{\frac{\rho}{T}}r\right) \cos(\omega t)$$

The series tells us some of the properties that we need, and the differential equation

$$J_0'' + \frac{1}{x}J_0' + J_0 = 0$$

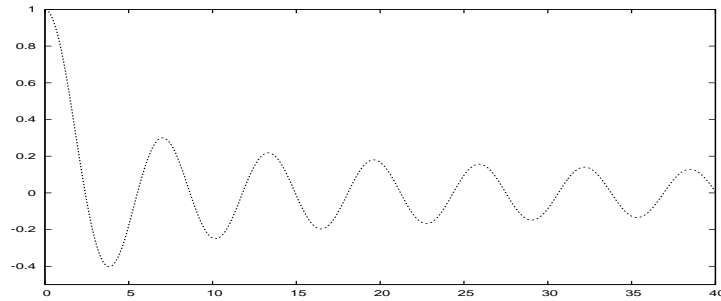

Figure 34: Graph of Bessel function  $J_0(x) = 1 - \frac{x^2}{2^2} + \frac{x^4}{2^2 4^2} - \frac{x^6}{2^2 4^2 6^2} + \dots$

itself gives other properties.

First the series: The series is reminiscent of that for the cosine function, so maybe  $J_0$  has many zeros, and oscillates, and is periodic. Well, 2 out of 3 isn't bad:  $J_0$  has infinitely many zeros and oscillates somewhat like the cosine function, but is not periodic. In a homework problem you will use the series to find that  $J_0(4)$  is negative. Since we know  $J_0(0) = 1$ , there must be a number  $x_1$  between 0 and 4 where  $J_0(x_1) = 0$ . In fact the first root  $x_1$  is roughly 2.5 and the second root  $x_2$  is near 5.5,  $x_3$  is about 8.5, and there are infinitely many others.

From the differential equation we see this: suppose you have an interval like  $[x_1, x_2]$  where  $J_0$  is 0 at each end, and nonzero between. At any local min or max where  $J_0' = 0$ , the DE then tells us that  $J_0'' = -J_0$  there. The graph can't be concave up at a local max, nor concave down at a minimum. So the graph can only have simple humps like the cosine does, no complicated zig-zags between the roots.

After analyzing  $J_0$  like this for some time, people eventually published tables of its values, and many years later someone built it into `matlab` and `octave` so that we could look at the graph in Figure 34. Isn't that nice?

## 16.2 But what does the drum Sound like?

We don't know  $\omega$  yet. We don't know what sounds the drum can make.

We have two boundary conditions. The first is that  $u_r(0, t) = 0$ , so that the drum shape is not pointy in the center. This is automatic since it is a property of  $J_0$ .

PRACTICE: How do you know from the series

$$J_0(x) = 1 - \frac{x^2}{4} + \dots$$

that  $J_0'(0) = 0$ ?

The second boundary condition is that at the rim we have

$$u(1, t) = f_0 J_0\left(\omega \sqrt{\frac{\rho}{T}} \cdot 1\right) \cos(\omega t) = 0$$

To achieve this, we need

$$\omega \sqrt{\frac{\rho}{T}} = x_1$$

or  $x_2$  or some root of  $J_0$ . Then the lowest sound we hear will correspond to the case

$$u(r, t) = f_0 J_0(x_1 r) \cos\left(\sqrt{\frac{T}{\rho}} x_1 t\right)$$

The ordinary cosine function has period  $2\pi$ , so this cosine will go through one cycle as

$$\sqrt{\frac{T}{\rho}} x_1 t$$

goes from 0 to  $2\pi$ . One cycle in every  $\frac{2\pi}{\sqrt{\frac{T}{\rho}} x_1}$  seconds. The frequency is  $\sqrt{\frac{T}{\rho}} \frac{x_1}{2\pi}$ .

For larger roots  $x_2$  etc you get shorter cycles, higher pitched sounds.

PRACTICE: When you tighten up the drum tension  $T$ , do the frequencies go up or down? Also the drummer might change to a heavier material so that  $\rho$  increases. What does that do to the frequencies?

EXAMPLE: Take  $\rho = T$  for simplicity. We have a vibration

$$u_1(r, t) = J_0(x_1 r) \cos(x_1 t)$$

where  $x_1$  is approximately 2.5. This is a solution to the boundary value problem

$$\begin{aligned} u_{tt} &= u_{rr} + \frac{1}{r} u_r & (0 < r < 1) \\ u(1, t) &= 0 \\ u_r(0, t) &= 0 \end{aligned}$$

having initial position  $u_1(r, 0) = J_0(x_1 r)$ . Another solution is

$$u_2(r, t) = J_0(x_2 r) \sin(x_2 t)$$

where  $x_2$  is approximately 5.5. This has a different initial shape, and a different frequency, and a different initial velocity.

PRACTICE: What is the initial velocity of  $u_1$ ?

Any linear combination of these various solutions, for different roots  $x_n$ , and using both cosines and sines, is a solution to our wave equation.

PRACTICE: Check a specific case, that

$$u(r, t) = 3J_0(x_1 r) \cos(x_1 t) + 2J_0(x_3 r) \sin(x_3 t)$$

is a solution to  $u_{tt} = u_{rr} + \frac{1}{r}u_r$  with  $u(1, t) = 0$ . [It saves a lot of work if you remember that  $J_0''(x) + \frac{1}{x}J_0'(x) + J_0(x) = 0$ .]

So our model predicts what sounds the drum will make. Good.

#### PROBLEMS

97. In this problem you can confirm part of what is shown in the graph of  $J_0$ , that  $J_0(4) < 0$  so there must be a root  $x_1$  somewhere in the interval  $(0, 4)$ . Write the partial sum of  $J_0(x)$  through sixth powers as  $s_6(x)$

$$s_6(x) = 1 - \frac{x^2}{2^2} + \frac{x^4}{2^2 4^2} - \frac{x^6}{2^2 4^2 6^2}.$$

First check that  $s_6(4)$  is negative. It saves a little work if you notice that the second and third terms cancel.

98. In Problem 97 the tail of the series is so small that  $J_0(4)$  itself is also negative. That means,

$$J_0(4) = s_6(4) + E$$

where  $E$  is not very big and the sum is negative. Try to estimate  $E$  by observing that the tail is an alternating series, if you remember those from calculus.

99. Make a sketch of the graphs of  $J_0(x_1 r)$  and  $J_0(x_2 r)$  for  $0 \leq r \leq 1$ , so that you can see what some of the drum waves look like. You can figure these out from Figure 34 by rescaling.

100. For a particular real drum, it might be feasible to measure  $\rho$  if you could weigh a sample of the drumhead material, but  $T$  could present more problems. Suppose you compare the sound of the drum to a piano or guitar and decide that the fundamental tone is near the note  $A_2 = 110$  [cycles/sec], the next to lowest string on a guitar. Figure out  $\frac{T}{\rho}$  for this drum.



101. Remind yourself that the first three tones of a string have frequencies in the proportion  $1 : 2 : 3$ , i.e., there are solutions  $\cos(t) \sin(x)$ ,  $\cos(2t) \sin(2x)$ , and  $\cos(3t) \sin(3x)$  to the wave equation  $y_{tt} = y_{xx}$ . But what about a drum? Check the graph of  $J_0$  and find out approximately how the lowest three frequencies of a drum are related. This is why pianos and drums don't sound the same.

## 17 The Euler equation for Fluid Flow, and Acoustic Waves

TODAY: A model for compressible air flow, including sound. This example is a little more advanced than the rest of the lectures, so there are several practice items here to guide your reading.

The purpose of this lecture is to derive three PDEs which describe compressible flow of air in one dimension, say in a pipe. You might imagine pumping air into a bicycle tire through a hose, for example. The main assumptions are:

- There is no conduction of heat through the air. There is no friction of the air with the pipe, or any exchange of heat between the air and the pipe.
- You know about Newton's law  $F = ma$ , and about the idea of conservation of mass. And of course you know calculus.

Two of the three equations are known as the Euler equations for isentropic flow. [You do not have to know what "isentropic" means, but if you have read Lecture 7 you will have touched the idea.] Then having the Euler equations, we can further derive that certain approximate solutions are solutions to the wave equation. These solutions are very familiar—they are sound waves. Thus we also get, almost free, another derivation of the wave equation.

We have already derived the wave equation for vibrations of a string, and indicated a derivation for light waves (in Problem 10). Thus you see that there are three very different situations giving rise to the same mathematics.

The method used in this derivation is rather common in science. There are many assumptions behind every statement. So, to understand the derivation, you have to ask yourself at every step, Why should that be true? What is being assumed? This careful questioning can lead to good insights.

### The Euler equations

The pipe is full of air. The air velocity is  $u(x, t)$  [m/sec], and density  $\rho(x, t)$  [kg/m<sup>3</sup>]. For air, the density is typically around 1.2 near the surface of the earth,

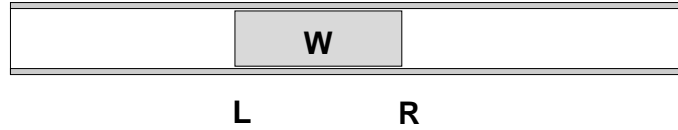

Figure 35: A portion of air moving in the pipe. The pipe has cross-sectional area  $A$ . The ends  $L$  and  $R$  don't have to move at the same speed because this is compressible flow.

but the velocity could vary over a large range. We can think of  $x$  and  $u$  positive toward the right.

We focus on a portion  $W$  of the air. The letters  $L$  and  $R$  in the figure refer to the left and right ends of the mass  $W$ .  $W$  is mathematically just a moving interval. The left coordinate  $L$  is moving at velocity  $u_L$ , and to be more precise,

$$L'(t) = u(L(t), t) \quad \text{and } u_L \text{ is an abbreviation for this}$$

and similarly for the right end  $R$  at velocity  $u_R$ .

Besides velocity  $u(x, t)$  and density  $\rho(x, t)$ , we must keep track of the air pressure  $p(x, t)$  [N/m<sup>2</sup>]. It is very easy to mistake  $\rho$  and  $p$  typographically, but this won't happen to you because you are reading very slowly and thinking hard, right? The pressure provides forces  $p_L A$  and  $p_R A$  on the left and right ends of  $W$ . The isentropic assumption is that the pressure is related to the density by  $p = a\rho^\gamma$ , where  $\gamma = 1.4$  and  $a$  is constant throughout the flow. [If you have worked Problem 36 on page 24 you will have seen this related to the "no heat added" assumption.] Aside from this thermodynamic assumption, the rest of our derivation will consist of ordinary mechanics.

Newton: The rate of change of momentum of the matter in  $W$  is equal to the sum of applied forces.

$$\frac{d}{dt} \int_L^R \rho u A dx = -p_R A + p_L A$$

PRACTICE: Is this really  $F = ma$  or is it more like  $\frac{d}{dt}(mv) = F$ ? When does the  $m$  in Newton's law have to be included inside the derivative? Of the quantities and expressions  $\rho$ ,  $u$ ,  $A$ , and  $\int dx$ , which constitute  $v$  and which  $m$ ? Why do we multiply pressure by area? Why is there a minus sign on  $p_R A$ ?

In the left side of Newton's law we need to remember that

$$\frac{d}{dt} \int_{g(t)}^{f(t)} h(x, t) dx = \int_{g(t)}^{f(t)} h_t(x, t) dx + h(f(t), t)f'(t) - h(g(t), t)g'(t)$$

PRACTICE: Derive that from the Fundamental Theorem of Calculus and the Chain Rule.

So, if we cancel all the  $A$ 's, Newton's law and the isentropic assumption give

$$\int_L^R (\rho u)_t dx + (\rho u)_R u_R - (\rho u)_L u_L = -p_R + p_L = -a\rho_R^\gamma + a\rho_L^\gamma$$

Now we may be able to study a limit of this for very short intervals. If it is possible to divide by  $R - L$  and take  $L \rightarrow R$ , then we get

$$(\rho u)_t + (\rho u^2 + a\rho^\gamma)_x = 0$$

This is a partial differential equation which of course assumes the various functions are differentiable. [We assume this. But it is important to know that the limit has been found not in agreement with all experiments. We won't go into 'shock waves' at all, but you should know that there are such possibilities.]

PRACTICE: Why does

$$\frac{f_R - f_L}{R - L}$$

tend to  $f_x$  as  $R$  and  $L$  tend to  $x$ ? Assume  $f$  differentiable.

We notice that we have two unknown functions,  $u$  and  $\rho$ . Probably one equation isn't going to be enough, so we look for another equation. Turning to conservation of mass, we figure the mass in  $W$  to be  $\int_L^R \rho A dx$ . This doesn't change as the fluid moves because our set  $W$  is moving with the fluid. We have conservation of mass

$$\frac{d}{dt} \int_L^R \rho A dx = 0$$

Doing the same transformations as we did for Newton gives

$$\int_L^R \rho_t A dx + (\rho u)_R A - (\rho u)_L A = 0$$

and in the limit

$$\rho_t + (\rho u)_x = 0$$

PRACTICE: Use  $\rho_t + (\rho u)_x = 0$  in the Newton PDE to find

$$u_t + uu_x = -a\gamma\rho^{\gamma-2}\rho_x$$

These two equations are the results of our work, the one-dimensional isentropic Euler equations,

$$\begin{aligned}\rho_t + (\rho u)_x &= 0 \\ u_t + uu_x &= -a\gamma\rho^{\gamma-2}\rho_x\end{aligned}$$

We can identify a physical meaning for the combination of terms  $u_t + uu_x$  which occurs in the equation of motion. In Problem 102 you can show that it is the acceleration of the particle which is passing through the point  $x$  at time  $t$ .

PRACTICE: Can there be any acceleration at a point where  $u_t = 0$ ?

## 17.1 Sound

Here we start from the Euler equations, and imagine a small disturbance superimposed over an ambient stillness.

PRACTICE: Is it true that the ambient stillness  $u = 0$ ,  $\rho = (\text{constant})$  is a solution to the Euler equations?

We then look for approximate solutions of the form

$$\begin{aligned}u(x, t) &= \epsilon v(x, t), \\ \rho(x, t) &= \rho_1 + \epsilon w(x, t)\end{aligned}$$

where  $\epsilon$  is a small number. The constant  $\rho_1$  could be taken to be a typical air density at sea level on earth.

PRACTICE: Substitute our assumed  $u$  and  $\rho$  into the Euler equations and ignore everything containing  $\epsilon^2$  or higher powers. Show that you find for the  $\epsilon^1$  terms,

$$\begin{aligned}v_t &= -a\gamma\rho_1^{\gamma-2}w_x \\ w_t + \rho_1 v_x &= 0\end{aligned}$$

Combining the two PDEs in that practice problem, we have

$$w_{tt} = -\rho_1 v_{xt} = a\gamma\rho_1^{\gamma-1}w_{xx},$$

or

$$w_{tt} = c^2 w_{xx}$$

where  $c^2 = \alpha\gamma\rho_1^{\gamma-1}$ . So the pressure disturbance satisfies the wave equation, with  $c$  the sound speed.

It is said that Newton himself underestimated the speed of sound because he assumed (who wouldn't?) that the temperature doesn't change when tiny sound waves pass by. But it is the entropy which does not change.

#### PROBLEMS

102. Suppose a particle of fluid has position given by a function  $x(t)$ . Then we have two expressions for the velocity of this particle,  $x'(t)$ , and  $u(x(t), t)$ . These must be equal. Differentiate to show that the composition  $(u_t + uu_x)(x(t), t)$  is equal to the acceleration of the particle.

103. Air pressure at sea level on the earth is about  $10^5$  [N/m<sup>2</sup>]. Using this and previous information, estimate the speed of sound. Remember that traveling waves  $f(x - ct)$  are solutions to the wave equation. If someone claps his hands at a distance of 3 football fields from you, how long before you hear it?

## 18 The Laplace Equation

TODAY: Two roads lead here. The heat conduction and drum vibration models both morph into the Laplace equation under certain conditions. Many roads lead away. The one we take will be the Fourier road.

The Laplace equation looks like this in two dimensions

$$u_{xx} + u_{yy} = 0$$

or in one  $u'' = 0$ , or in three  $u_{xx} + u_{yy} + u_{zz} = 0$ . In two dimensions using polar coordinates not at the origin it looks like

$$u_{rr} + \frac{1}{r}u_r + \frac{1}{r^2}u_{\theta\theta} = 0.$$

Solutions are called “harmonic” functions. In every case it says that the divergence of the gradient of  $u$  is 0,  $\text{div}(\nabla u) = 0$ . It is abbreviated  $\Delta u = 0$  by mathematicians and  $\nabla^2 u = 0$  by engineers. But what does it mean? We approach that from two directions, as follows.

**I.** The Laplace equation can apply to a steady state temperature. We know from Lecture 13 that the temperature in a region is modeled by the heat equation  $u_t =$

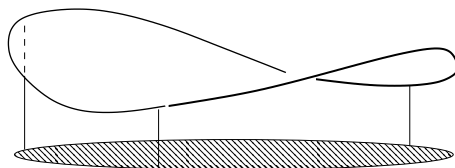

Figure 36: A membrane stretched, or the graph of a steady temperature.

$\Delta u$ , which keeps track of the conduction of heat energy from hot places to cold places. If the temperature is not changing with time, that gives the Laplace equation. It doesn't mean there is no energy flow. A refrigerator can maintain a constant temperature but only by forcing out the energy that seeps in through the walls. We will consider the polar coordinate case in a disk with the temperature  $u$  specified on the boundary circle.

**II.** Our drum discussion in Lecture 16 can be modified. There we had a dynamic situation  $u_{rr} + \frac{1}{r}u_r = u_{tt}$  with circular symmetry. If you instead analyze a circular membrane stretched statically over a varying rim height, you find for small angles that the same Laplace equation  $u_{rr} + \frac{1}{r}u_r + \frac{1}{r^2}u_{\theta\theta} = 0$  applies to the displacement  $u$ . What is added is the  $\theta$  dependence including nonzero boundary conditions, and what is removed is the time dependence.

So we are solving the boundary value problem

$$u_{rr} + \frac{1}{r}u_r + \frac{1}{r^2}u_{\theta\theta} = 0 \quad (0 < r < 1, 0 \leq \theta \leq 2\pi)$$

with a specified value at the boundary circle

$$u(1, \theta) = f(\theta).$$

PRACTICE: What can we try? We have traveling waves, product solutions, power series. Anything else?

Let's look for product solutions  $u(r, \theta) = R(r)F(\theta)$ . You get

$$R''F + \frac{1}{r}R'F + \frac{1}{r^2}RF'' = 0.$$

We need to divide by  $F$  at least:

$$R'' + \frac{1}{r}R' + \frac{1}{r^2}R\frac{F''}{F} = 0.$$

That is not quite separated. Multiply by  $\frac{r^2}{R}$ :

$$\frac{r^2 R'' + r R'}{R} + \frac{F''}{F} = 0.$$

Now what do we have? The  $R$  part doesn't look at all familiar. How about the  $F$ ? Well, there is no doubt about that. We need  $F''$  to be a constant multiple of  $F$ , and we know that equation very well by now. The possibilities for  $F(\theta)$  are  $\cos(a\theta)$ ,  $\sin(a\theta)$ ,  $e^{a\theta}$ ,  $e^{-a\theta}$ , and  $a\theta + b$ , for various numbers  $a$ ,  $b$ , or certain linear combinations of those. Since we want  $u$  continuous in  $\theta$  if possible, it has to connect smoothly when  $\theta$  loops around to  $2\pi$  which is the same angle as 0. So we better not use  $a\theta + b$  unless  $a = 0$ . A constant is ok, say  $b = 1$  for definiteness. Also any of the  $\sin(n\theta)$  or  $\cos(n\theta)$  for  $n \geq 1$  would be alright. So far our list of acceptable functions  $F$  is

$$1, \cos(\theta), \sin(\theta), \cos(2\theta), \sin(2\theta), \cos(3\theta), \sin(3\theta), \dots$$

and these will be enough for our purposes. We'll abbreviate the list as

$$\cos(n\theta), \quad \sin(n\theta), \quad (n \geq 0).$$

Then

$$\frac{F''}{F} = -n^2.$$

PRACTICE: 1. Convince yourself of that  $-n^2$ .

2. Would  $u(r, \theta) = \sin(\frac{1}{4}\theta)$  be continuous on the  $x$  axis if we are thinking of running  $\theta$  from 0 to  $2\pi$ ?

With those choices for  $F$ , the requirement on  $R$  is that  $\frac{r^2 R'' + r R'}{R} - n^2 = 0$ , or

$$r^2 R'' + r R' - n^2 R = 0 \quad (n \geq 0)$$

Now what? This is a second order linear differential equation, but look at the coefficients. They are not constants. So we can't use the characteristic equation method; that is based on trying exponentials and it won't work with variable coefficients.

PRACTICE: In case that isn't clear, substitute  $R(r) = e^{kr}$  to see why it doesn't work.

We can still try something else. We haven't tried a power series for a while. As it happens, the solution for this is the easiest power series you've ever tried. It is left for the Problems. In the next section we'll continue with  $u$ .

## PROBLEMS

104. Having no other good ideas about the unfamiliar  $R$  equation  $r^2 R'' + rR' - n^2 R = 0$ , we could try a power series

$$R(r) = a_0 + a_1 r + a_2 r^2 + \dots$$

But wait. It works out so nicely I would like to save you some work. Try just

$$R(r) = r^a$$

If that doesn't work, you can always try something harder. You will like this one.

105. Combine your solution for  $R$  in Problem 104 with its corresponding  $F(\theta)$  that we found, and check it in the Laplace equation to make sure that you really do have a solution. Try it for a couple of different values of  $n$ .

## 18.1 Laplace leads to Fourier

We are solving the boundary value problem

$$u_{rr} + \frac{1}{r} u_r + \frac{1}{r^2} u_{\theta\theta} = 0 \quad (0 < r < 1, 0 \leq \theta \leq 2\pi)$$

with a specified value at the boundary circle

$$u(1, \theta) = f(\theta)$$

and so far you have found (you did Problem 105, no?) a list of solutions to the Laplace equation:

$$r^n \cos(n\theta), \quad r^n \sin(n\theta), \quad (n > 0) \quad \text{and also } 1.$$

Now we have to think about the boundary conditions.

PRACTICE: What does the boundary look like for the case  $u(r, \theta) = r \sin(\theta)$ ? What is  $r \sin(\theta)$  anyway?

EXAMPLE: Suppose the boundary condition is that

$$u(1, \theta) = f(\theta) = 6 \cos(3\theta)$$

Of our list of solutions to Laplace, the one which stands out is

$$r^3 \cos(3\theta)$$



It is almost what we need. Would it be alright to multiply it by 6? (yes, see Problem 106.) So one solution to the BVP is

$$u(r, \theta) = 6r^3 \cos(3\theta)$$

Some people call the graph in Figure 36 a saddle, and this  $r^3 \cos(3\theta)$  a monkey saddle. Can you see why?

EXAMPLE: If the boundary condition is now

$$u(1, \theta) = f(\theta) = 6 \cos(3\theta) + 3 \sin(6\theta)$$

what will the solution be? We can try a linear combination

$$u(r, \theta) = c_1 r^3 \cos(3\theta) + c_2 r^6 \sin(6\theta)$$

At least that will be a solution to the Laplace equation (see Problem 108). Then we have to choose the coefficients  $c_k$  if possible to get the boundary values. It will work to take  $c_1 = 6$  and  $c_2 = 3$ . Answer:

$$u(r, \theta) = 6r^3 \cos(3\theta) + 3r^6 \sin(6\theta)$$

Look, you just throw the  $r^n$  factors in. After all this buildup, does that seem strange?

## Fourier

M. Fourier observed the examples we've seen. He felt that something is missing. Of course you probably feel too that our boundary conditions are somewhat artificial, made to fit the product solutions we found. Fourier wondered if you could work with some such boundary conditions as

$$u(1, \theta) = f(\theta) = \theta^2$$

which has nothing to do with the cosines and sines. It is an interesting question to ask. Could it be possible that you could somehow expand  $f$  in terms of cosines and sines? Could a function  $f(\theta)$  which is not expressed in terms of the  $\cos(n\theta)$  and  $\sin(n\theta)$  actually have those hidden within it?

The question is more strange too, because it is nearly the opposite of what we are used to, like

$$\cos(\theta) = 1 - \frac{\theta^2}{2} + \frac{\theta^4}{24} - \dots$$

That goes the wrong way—we wanted  $\theta^2$  in terms of trig functions. Eventually we will achieve this on page 91. But if the answer to the question is yes, then you can solve the membrane problem by just putting in the powers of  $r$  as we did above:

$$\text{If } f(\theta) = c_0 + a_1 \cos(\theta) + b_1 \sin(\theta) + a_2 \cos(2\theta) + b_2 \sin(2\theta) + \dots$$

then you can solve the boundary value problem as follows, assuming convergence:

$$u(r, \theta) = c_0 + r(a_1 \cos(\theta) + b_1 \sin(\theta)) + r^2(a_2 \cos(2\theta) + b_2 \sin(2\theta)) + \dots$$

Isn't that remarkable?

#### PROBLEMS

106. We need to check carefully that when  $u$  is a solution to the Laplace equation, then so is  $\delta u$ , or  $cu$  for any constant  $c$ . How can that be checked? Start with the first order derivative

$$\frac{\partial u}{\partial r}$$

Is it true that  $\frac{\partial cu}{\partial r} = c \frac{\partial u}{\partial r}$ ? Then how about the second derivatives, say  $(cu)_{\theta\theta}$ ? Is that the same as  $c(u_{\theta\theta})$ ? That is the essential idea behind the fact that

$$\nabla^2(cu) = c\nabla^2 u$$

Why does that prove what we need?

107. We also need to know that a sum of two harmonic functions is harmonic. Reason that out similarly to Problem 106.

108. We also need to understand that any linear combination of harmonic functions is harmonic. Part of the calculation goes like this.

$$\nabla^2(c_1 u_1 + c_2 u_2) = \nabla^2(c_1 u_1) + \nabla^2(c_2 u_2) = c_1 \nabla^2(u_1) + c_2 \nabla^2(u_2)$$

Which part of that is by Problem 106? 107? Why does that prove what we need?

## 18.2 Fourier's Dilemma

We now know that it is easy to solve the boundary value problem

$$u_{rr} + \frac{1}{r} u_r + \frac{1}{r^2} u_{\theta\theta} = 0 \quad (0 < r < 1, 0 \leq \theta \leq 2\pi)$$

with a specified value at the boundary circle  $u(1, \theta) = f(\theta)$  *provided* that we can express  $f(\theta)$  in terms of a series made from our list

$$\cos(n\theta), \quad \sin(n\theta), \quad (n > 0) \quad \text{and also } 1.$$

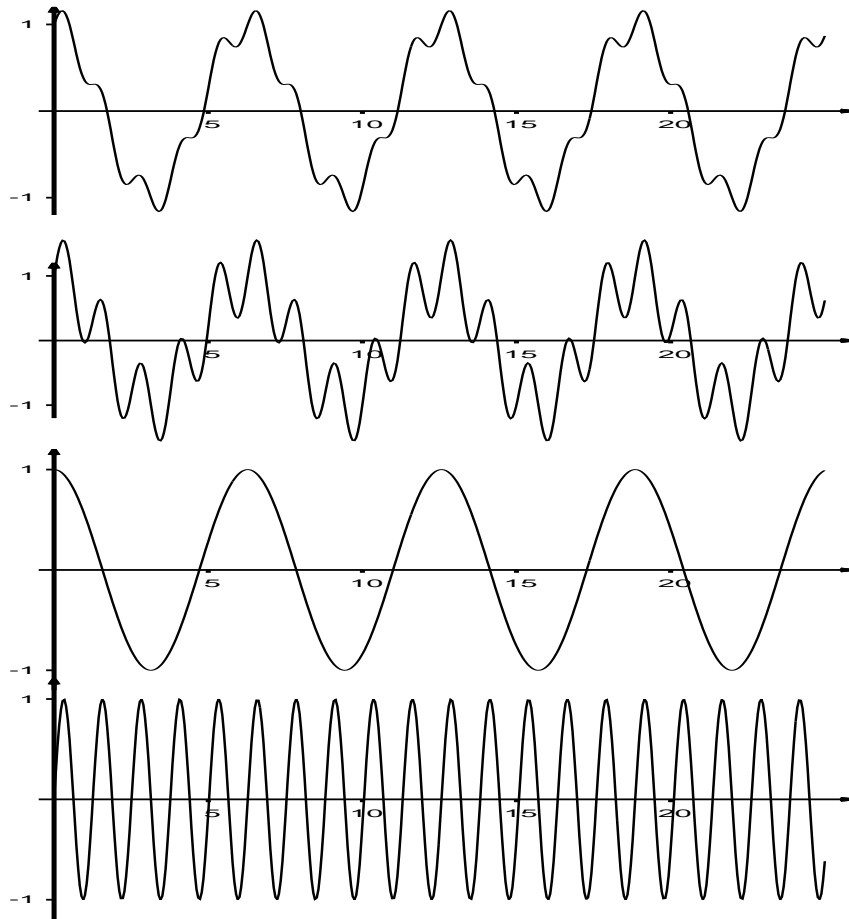

Figure 37: *Top:* What frequencies could be hidden in this function? *Second:* How about now? The function has been modified a little to make some features stand out. Compare to the last two. *Third:* The graph of  $\cos(\theta)$ . *Last:* The graph of  $\cos(6\theta)$ .

Fourier wanted to know how to extract the frequencies hidden in  $f$ .

PRACTICE: Try to estimate the coefficient  $c$  visually if the top function graphed in Figure 37 is

$$\cos(\theta) + c \cos(6\theta).$$

You see from the practice problem that you can sometimes visually estimate the hidden information if it is not too deeply hidden. Fourier wanted to dig further. We'll dig all the way to the bottom in the next section. For now we take special identities that you know about.

EXAMPLE: 1. You probably remember  $\cos^2(\theta) = \frac{1}{2} + \frac{1}{2} \cos(2\theta)$ .  
2. From the complex exponential identity  $e^{3i\theta} = (e^{i\theta})^3$  we can derive that

$$\cos^3(\theta) = \frac{3}{4} \cos(\theta) + \frac{1}{4} \cos(3\theta)$$

So there are at least two functions not originally given as a linear combination of the  $\cos(n\theta)$  and  $\sin(n\theta)$ , for which we have a Fourier series. There are just two terms in each.

We can think of the numbers 1 and 3 as the hidden (circular) frequencies and the coefficients  $\frac{3}{4}$  and  $\frac{1}{4}$  are hidden amplitudes in the function  $\cos^3(\theta)$ . We got those examples sort of by luck, by trig identities. In the next lecture we will find out a systematic method for getting this information.

#### PROBLEMS

109. Suggest a reason why  $c$  in the practice problem must be positive.  
110. Sketch a graph of the  $\cos^3(\theta)$  and sketch the two terms in its Fourier series separately to see how they fit together. A linear combination of sinusoids is not usually a sinusoid.

### 18.3 Fourier answered by Orthogonality

We have seen only two cases where a function which was not originally expressed as a linear combination of sinusoids in fact is one. One example was

$$\cos^3(\theta) = \frac{3}{4} \cos(\theta) + \frac{1}{4} \cos(3\theta)$$

But we also know there are good reasons to find these hidden frequencies if they exist, to solve the Laplace equation for example. If there were only two examples, we wouldn't bother.

After Fourier's time a concept was developed to extract the hidden information from other functions. It is called "orthogonality" of functions. It works like this. People knew that

$$\int_{-\pi}^{\pi} \cos(\theta) \sin(\theta) d\theta = 0$$

because an antiderivative is  $\frac{1}{2} \sin^2(\theta)$ .

PRACTICE: Check that.

And there are a lot of other similar integrals which are 0.

EXAMPLE: You don't really need an antiderivative, because  $\cos(\theta) \sin(\theta)$  is an *odd* function: the graph has the kind of symmetry where each positive part to the right of 0 is balanced by a negative part to the left of 0, and vice versa. So it must integrate to 0. By the same argument,

$$\int_{-\pi}^{\pi} \cos(n\theta) \sin(m\theta) d\theta = 0$$

for all  $n$  and  $m$ .

Functions  $f$  and  $g$  are called "orthogonal" on  $[-\pi, \pi]$  if

$$\int_{-\pi}^{\pi} f(\theta)g(\theta) d\theta = 0.$$

You can compare this to the dot product of vectors:

$a_1\vec{i} + a_2\vec{j} + a_3\vec{k}$  and  $b_1\vec{i} + b_2\vec{j} + b_3\vec{k}$  are orthogonal if

$$a_1b_1 + a_2b_2 + a_3b_3 = 0$$

The integral is a sum, or at least a limit of sums, and the values of the functions play the role of coordinates. This was a very new idea, to use geometric language to discuss functions.

We saw above that each of the  $\cos(n\theta)$  is orthogonal to all the  $\sin(m\theta)$ . It is also true (see Problem 116) that any two of the cosines are orthogonal to each other. Also any two of the sines are orthogonal to each other, and all those trig functions are orthogonal to the constant function 1. So there is a long list of functions, any two orthogonal,

$$1, \cos(\theta), \sin(\theta), \cos(2\theta), \sin(2\theta), \cos(3\theta), \sin(3\theta), \cos(4\theta), \sin(4\theta), \dots$$

sort of like  $\vec{i}, \vec{j}, \vec{k}$  in 3-dimensional space. We have a lot more than 3 orthogonal functions though, since in effect we are now working in an infinite number of dimensions. This is a new concept, part of our new language.

But what else does that get you? It gets you *everything*. Why: Suppose it is possible to write a function  $f$  as

$$f(\theta) = c_0 + a_1 \cos(\theta) + b_1 \sin(\theta) + a_2 \cos(2\theta) + b_2 \sin(2\theta) + \dots$$

but that we do not yet know what the hidden coefficients  $c_0, a_n, b_n$  are. Here is a way to find them. Think about the vector case, where a vector  $\vec{v}$  can be written

$$\vec{v} = a_1 \vec{i} + a_2 \vec{j} + a_3 \vec{k}$$

but somehow we do not know what the coefficients are yet. Dot with  $\vec{j}$ , for example. You find the number  $a_2$  by doing a dot product:

$$\vec{v} \cdot \vec{j} = a_1 \vec{i} \cdot \vec{j} + a_2 \vec{j} \cdot \vec{j} + a_3 \vec{k} \cdot \vec{j} = 0 + a_2 + 0 = a_2$$

by the orthogonality and the fact that  $\vec{j}$  is a unit vector. So we can try the same thing with functions, for example

$$\begin{aligned} \int_{-\pi}^{\pi} f(\theta) \cos(2\theta) d\theta &= \\ \int_{-\pi}^{\pi} c_0 \cos(2\theta) d\theta + \int_{-\pi}^{\pi} a_1 \cos(\theta) \cos(2\theta) d\theta + \int_{-\pi}^{\pi} b_1 \sin(\theta) \cos(2\theta) d\theta \\ + \int_{-\pi}^{\pi} a_2 \cos(2\theta) \cos(2\theta) d\theta + \int_{-\pi}^{\pi} b_2 \sin(2\theta) \cos(2\theta) d\theta + \int_{-\pi}^{\pi} a_3 \cos(3\theta) \cos(2\theta) d\theta + \dots \\ &= 0 + 0 + 0 + a_2 \int_{-\pi}^{\pi} \cos(2\theta) \cos(2\theta) d\theta + 0 + 0 + \dots \end{aligned}$$

We still need to know that remaining integral  $\int_{-\pi}^{\pi} \cos(2\theta) \cos(2\theta) d\theta$ . Its value is  $\pi$ :

$$\int_{-\pi}^{\pi} \cos^2(2\theta) d\theta = \int_{-\pi}^{\pi} \frac{1}{2} (1 + \cos(4\theta)) d\theta;$$

the 1 integrates to  $\pi$  and the  $\cos(4\theta)$  integrates to zero: it is orthogonal to 1.

These ideas lead to the Fourier coefficient formulas

$$a_n = \frac{1}{\pi} \int_{-\pi}^{\pi} f(\theta) \cos(n\theta) d\theta,$$

$$b_n = \frac{1}{\pi} \int_{-\pi}^{\pi} f(\theta) \sin(n\theta) d\theta,$$

and

$$c_0 = \frac{1}{2\pi} \int_{-\pi}^{\pi} f(\theta) d\theta$$

Of course we only derived the  $a_2$  case but the ideas work for all. We have shown that if  $f$  has a Fourier series then these must be the coefficients. It is a uniqueness argument. It is for another course to study which functions actually have Fourier series.

#### PROBLEMS

111. Take a short Fourier series such as

$$f(\theta) = \cos(\theta) + 0.3 \sin(5\theta).$$

Sketch the graph of the two terms and of  $f$  to see how they fit together and how the sum no longer has a graph like that of a trig function.

112. Same as Problem 111 for

$$f(\theta) = \cos(9\theta) + \cos(10\theta)$$

This one is hard to do by hand, but is interesting because you get to see an example of amplitude modulation, AM. Compare Figure 13 on page 31.

113. Work out the Fourier coefficient integrals for the function  $f(\theta) = \theta^2$ . You'll need to integrate by parts twice. The result ought to be the series

$$\theta^2 = \frac{\pi^2}{3} - 4 \cos(\theta) + \frac{4}{2^2} \cos(2\theta) - \frac{4}{3^2} \cos(3\theta) + \frac{4}{4^2} \cos(4\theta) - \frac{4}{5^2} \cos(5\theta) + \dots$$

It is for another course to discuss the convergence of Fourier series, but this series converges to  $\theta^2$  for  $-\pi \leq \theta \leq \pi$ . Of course this series cannot be correct for all values of  $\theta$  because the series is periodic, and  $\theta^2$  is not. This series answers Fourier's question on page 85.

114. Use the series in Problem 113 to solve the problem

$$\begin{aligned} \Delta u &= 0 \\ u(1, \theta) &= \theta^2 \end{aligned}$$

in the unit disc, where  $-\pi \leq \theta \leq \pi$ .

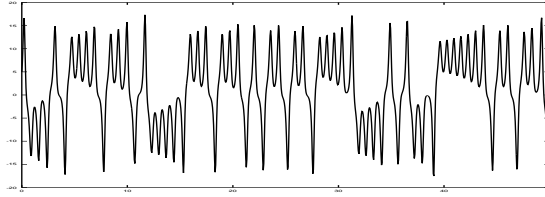

Figure 38: A chaotic motion.

115. [Harder] Show that the drum vibrations

$$u_1(r, t) = J_0(x_1 r) \cos(x_1 t), \quad u_2(r, t) = J_0(x_2 r) \cos(x_2 t)$$

are orthogonal on the drumhead whenever  $x_1$  and  $x_2$  are two roots of  $J(x) = 0$ . That means

$$\iint_{\text{unitdisk}} u_1(r, t) u_2(r, t) r dr d\theta = 0.$$

116. Use the complex exponential  $e^{it} = \cos t + i \sin t$  in the form  $\cos t = \frac{1}{2}(e^{it} + e^{-it})$  to show that

$$\int_{-\pi}^{\pi} \cos(3\theta) \cos(4\theta) d\theta = 0.$$

The point is that exponentials are easy to integrate. Argue that for the same reasons any two of  $\sin(n\theta)$ ,  $\sin(m\theta)$  are orthogonal.

## 19 Application to the weather?

TODAY: Nonlinear systems in space. Chaos. Why we can't predict the weather.

There are systems for which the study of linear equations does not prepare you. Notice in Figure 38 that the function plotted there is more complicated than those in Figures 20 (page 46) and 37 (page 87); in a sense we can't discern what all the frequencies are. This lecture is only the briefest kind of introduction to this subject.

We begin with a linear example in which your knowledge of linear systems does help you understand a 3D system. Consider the system

$$\begin{aligned} x' &= -y \\ y' &= x \\ z' &= -z \end{aligned}$$



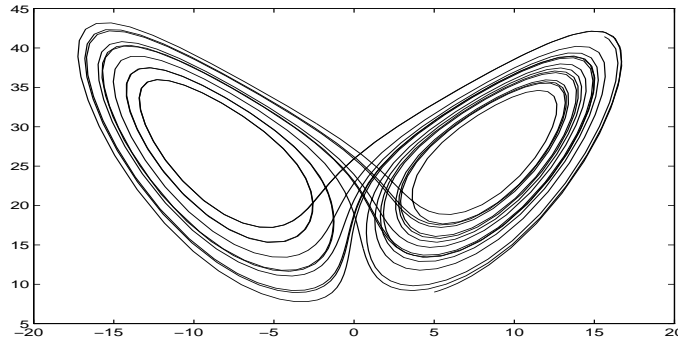

Figure 39: The Lorenz system. A solution curve  $(x(t), y(t), z(t))$  in 3 dimensions is here projected onto a plane. How do you suppose it occurred to Lorentz, to think of the effect of a butterfly on the weather?

These equations may be read as follows. The equation for  $z$  does not involve  $x$  or  $y$ , and vice versa. In fact the  $z$  equation is a simple equation for exponential decay. The  $x$  and  $y$  equations are a system corresponding to our favorite second order equation  $x'' = -x$  whose solutions are sines and cosines. Consequently we can think of this system as having a circular motion in the  $(x, y)$  plane combined with an exponential decay in the  $z$  direction. So the solutions are curves in 3-space moving around circular cylinders centered along the  $z$  axis, and which approach the  $(x, y)$  plane as time goes by. Any solution already in that plane remains there, circling.

In contrast with that system let us look at the Lorenz system

$$\begin{aligned}x' &= 10(y - x) \\y' &= -xz + 28x - y \\z' &= xy - \frac{8}{3}z\end{aligned}$$

See Figure 39. This very interesting system was made by Edward Lorentz who was a meteorologist at MIT, as a very simplified model of circulation in the atmosphere. The system is nonlinear because of the  $xz$  and  $xy$  terms, and is derived from much more complicated equations used in fluid mechanics. You may be interested to know that the weather predictions we all hear on the radio and TV are to some extent derived from calculations based on observational data and the real fluid mechanics equations.

There seem to be two critical points about which the solutions circulate. One finds that the solution turns a few times around the left one, then moves over to the right one for a while, then back, and so on. The only problem is that it is not easy to

predict how many times it will circle each side before moving to the other! Lorentz came upon this fact as follows. He was approximating solutions to this system on a computer in 1963, and noticed the pattern of random-looking jumps from one side to the other. These were very interesting solutions, so he reran the computation from a point part way along, to study it in more detail. In the process, he typed in as initial conditions the numbers which had been printed out by his program. These numbers were slightly rounded by comparison with the precision to which they had been computed. The result made history: the qualitative features were still there, but the solution in detail was very different, in that after a few turns the numbers of cycles around the left and right sides came out different, just because of rounding off a few decimal places in the initial conditions. That means that if you try to make a picture like the one above, it will look qualitatively the same, but may be different in detail. It also means something about weather prediction. Lorentz asked, “Does the Flap of a Butterfly’s Wings in Brazil Set Off a Tornado in Texas?” This is a restatement of the effect of rounding off, i.e. slightly changing, the initial conditions. Everybody has known for years that weather prediction is an art, that you really can’t predict the weather very well. Part of what Lorentz did was to explain *why* you can’t predict the weather: you can never know enough about the initial conditions no matter how many weather stations you build, when the equations of motion are so sensitive to initial conditions.

We also have a shift in the way the universe is conceived, as a result of studying this and other chaotic systems. On the one hand there is the uniqueness theorem which says that the future is determined uniquely by the initial conditions. This is the Newtonian approach. On the other hand we now know about chaotic systems in which yes, solutions might be uniquely determined by their initial conditions, but they may be so sensitive to these conditions that as a practical matter we cannot use the predictions very far into the future. Isn’t that interesting? It is a really major idea.

#### PROBLEMS

117. Check out the java applet [de](#) which is mentioned on page 16 and run some chaotic systems on it. Several are built in as examples.

118. Solve a 3D system in octave. Set up a function file to compute your vector field, like

```
% file ef.m
function wdot = ef(w,t)
wdot(1)=10*(w(2)-w(1));
wdot(2)=-w(1)*w(3)+28*w(1)-w(2);
wdot(3)=w(1)*w(2)-8*w(3)/3;
```

Then give commands like

```
octave:1> t = linspace(0,50,1000)';
octave:2> w = lsode("ef",[5 7 9],t);
octave:3> plot(w(:,1),w(:,3))
```

This will compute the solution to the Lorentz system for  $0 \leq t \leq 50$  with initial conditions  $(5, 7, 9)$ , and make a plot. The symbol  $w$  was used here for  $(x, y, z)$ , so what was plotted was  $x$  versus  $z$ . ( $w(:, 1)$  means  $x$ .) Naturally you can play with the `plot` command to get different views. Change these files to solve a system of your choice. Note that you are not restricted to just three dimensions either.

119. Change the `plot` command in Problem 118 to plot  $x$  versus  $t$ . This is the method by which Figure 38 was made.

120. Change the `ef.m` file of Problem 118 to solve the linear system described in the text. You will have to play with the `plot` command to get a nice perspective view, for example you can plot  $x$  versus  $y + 2z$  or something like that. Does the picture fit the description given in the text?

## Index

- bank, 1
- chain rule, 10
- characteristic equation, 33
- complex
  - exponential, 36
  - number, 34
- differential equation, 1
  - partial, 5
  - reading, 1
- eigenvalue, 48
- first order linear, 19
- fundamental theorem
  - algebra, 38
  - calculus, 8
  - differential equations, 15
- gravity, 6
- heat equation, 49
- ideal gas, 22
- initial condition, 4
- integrating factor, 20
- Laplace equation, 81
- linear combination, 29
- logistic equation, 11
- Maxwell, 6
- octave, 16
- oscillation
  - forced, 39
  - mode, 46
- pizza, 5
- response curve, 41
- separate variables
  - Laplace equation, 83
  - ode, 3, 12, 14
- slope field, 2
  - octave program, 18
- wave equation, 65